

Installation and operating manual for
FIXED VERTICAL LADDERS

DIN 18799-1, DIN 14094-1, DIN EN ISO 14122-4

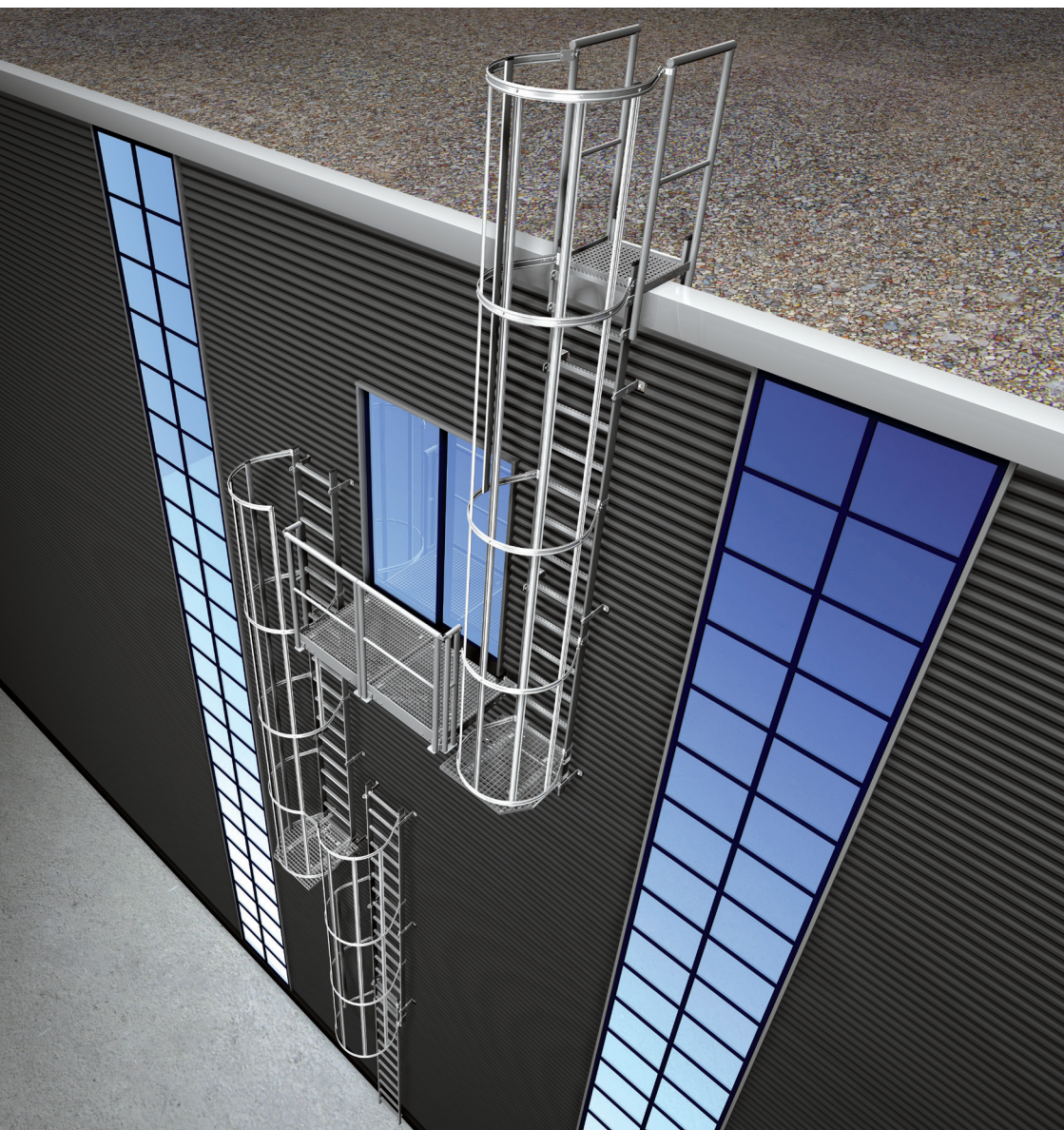

Introduction

Dear Customer,

with the purchase of the fixed ladder system you have chosen a quality product from Hailo.

We would like to thank you for your trust in our product.

This installation and operating manual describes the installation, use and maintenance and inspection of the fixed ladder system with standard wall brackets.

Please read this manual completely and observe all safety precautions before you begin the installation work and start using the fixed ladder.

Damage caused by failure to observe these instructions and safety precautions will invalidate the warranty. We are not liable for the resulting consequential damage.

The fixed ladder systems described in this installation and operating manual meet the standards DIN EN ISO 14122-4, DIN 18799-1 and DIN 14094-1.

The main components of the fixed ladder systems have been type-tested by the testing and certification body for structural facilities at

DEKRA Testing & Certification GmbH
Handwerkstraße 15, 70565 Stuttgart.

&

TÜV Austria Service GmbH
Deutschstraße 10
A-1230 Wien

If you have any questions or suggestions regarding our fixed ladder system, please call us.

We will be at your full disposal.

Hailo-Werk, Rudolf Loh GmbH & Co. KG
Daimlerstraße 2, 35708 Haiger, Germany

 +49 (0) 2773 82-0

 +49 (0) 2773 82-1332

E-Mail: info@hailo-professional.de
www.hailo-professional.de

IMPORTANT TELEPHONE NUMBERS:

We recommend each user to store the following telephone numbers in their mobile phone.

Emergency:

.....

Fire department:

.....

Operator of the system:

.....

Hailo service number:

.....

Other important telephone numbers:

.....

.....

.....

.....

Contents:

<i>Introduction</i>	2
1. <i>Preliminary Notes</i>	4
2. <i>Safety Notes</i>	6
3. <i>Standards and Regulations</i>	7
4. <i>Planning and Use of a Vertical Ladder System</i>	8
5. <i>Warranty and Liability</i>	9
6. <i>System Description</i>	10
7. <i>General Installation Instructions</i>	14
8. <i>Mounting the Fixed Ladder</i>	26
9. <i>Labels and Notes</i>	48
10. <i>Maintenance and Care</i>	50
11. <i>Inspection of the Fixed Ladder</i>	50
12. <i>Installation / Acceptance Report</i>	52
13. <i>Inspection Plan</i>	56
14. <i>Documentation of the Inspection</i>	58

1. Preliminary Notes

How to use the installation and operating manual



The installation and operating manual should be read carefully and taken into consideration before installing and before using the fixed ladder system.

The operator must ensure that the installation and operating manual is stored on site (or at a suitable location) where a ladder system is in use and that it is made available at any time for the the users.

Texts or drawings that are highlighted by symbols distinguish particularly important content and dangerous situations.

Failure to follow these instructions can cause injury or even death.

Symbols used in the manual:



General warning



Risk of falling



General instruction



Take note of the documentation



Use personal protection equipment (PPE) against falling



Tip, additional note

General regulations



The workplace ordinance demands that an authorised and qualified person inspects the ladders (including accessories) regularly to make sure that they are in good condition.

The time intervals for the inspections are to be determined by the employer (operator) and depend on the operating conditions.

Checklists may be obtained free of charge from Hailo.



Operators have the responsibility to:

- ensure compliance with local, state and federal regulations,
- adhere to the rules and standards (laws, regulations, guidelines, etc.) listed within the installation and operation manual to ensure safe handling,
- ensure that the installation and operating manual is made available to the installation personnel before an installation job is carried out and that the instructions – notes, cautions and safety regulations – are followed in all their aspects,
- consider that ladders in accordance with DIN EN ISO 14122-4, DIN 18799-1, DIN 14094-1 each have different requirements regarding design and installation.

2. Safety Notes



Instructions for installing and using the fixed ladder



Failure to observe the safety instructions on page 6 and 7 will invalidate the manufacturer's warranty!

Fall Protection:

According to DIN 18799-1 and DIN EN ISO 14122-4 fall protection is required for heights $\geq 3\text{m}$.

According to DIN 14094-1 „fire-escape ladders“, guardrails in accordance with EN 353-1 are not to be used.

Only a back-guard is permitted.

According to DIN 18799-1 and DIN EN ISO 14122-4 for heights above 10m and single-section ladders only fall protection according to EN 353-1 is allowed.

The safety notes and regulations must be followed to ensure an error-free installation and use of the ladder.

This installation and operating manual should be read by anyone who installs and uses the ladder.

Furthermore, the applicable on-site regulations on accident prevention must be followed.

- Before using the ladder make sure that there is enough free space within the workplace below the user so that it would not be possible to fall on an obstacle in the case of falling off the ladder.
- Before using the fixed vertical ladder it must be inspected visually.
- The user must be physically and mentally capable of climbing the ladder.
If the user needs to take medication, it is necessary to check the adverse effects that may have an influence or cause physical harm when using the system.
- Before starting work on the system the user of the ladder must consult with the operator regarding the initiation and implementation of emergency procedures.
- Also in order to be able to recognize potential hazardous points, the user should be aware of the specific local conditions in advance.
- When installing and using accessories for this system, the supplied instructions are to be followed carefully.
- The ladder is only to be used for its intended use and it must be in perfectly safe condition.
- Gloves must be worn when installing and using the vertical ladder.
- The ladder must be secured against unauthorised use.

3. Standards and Regulations

- The system or parts of the system are to be immediately withdrawn from use if any doubts arise regarding their safe condition.
This must be done by the manufacturer or another qualified person.
- It is not permitted to make modifications or enhancements to the equipment without the prior written approval of the manufacturer.
- Any necessary repairs must be carried out in accordance with the procedures that are specified by the manufacturer.
- During installation, maintenance or repair work make sure that no scaffolding, platforms or other things extend into the fall area and thus resulting in an additional fall hazard.



If using a ladder with a back-guard then an additional fall arrest system according to DIN EN 353-1 cannot be used.

Reason: a rescue operation is not possible due to space reasons.

DGVU 1

General rules and regulations

DGVU C38

Construction work

DGVU 312-906

Principles for selecting, training and certifying the capability of experts on personal safety equipment to protect against falling

DIN 18799-1

Ladders for construction works

DIN 14094-1

Fire-escape ladders

DIN EN ISO 14122-4

Safety of machines –permanent means of access to machinery– „Fixed Ladders“

4. Planning and Use of a Vertical Ladder System

DIN 18799-1:2021-02

- Fixed vertical ladders are to be arranged at an angle of inclination of more than 75° to 90° to the horizontal.
- Measures must be taken to prevent unauthorised persons from climbing the fixed ladder.
- Normally devices for securing personnel are required at exit platforms and are to be provided as guard rails attached to the vertical ladder on both sides wherever possible - see DIN 18799-3:2021-02.
- When installing on chimneys, points 4.6.5.4 and 4.7.2.2 of DIN 18799-1:2021-02 must be observed.
- The space between the vertical ladder and the surrounding area must be 650 mm from the front edge of the ladder rung (600 mm in the case of obstructions). Access openings must be at least equivalent to the area enclosed by the back guard system.

DIN EN ISO 14122-4:2016-10

- If necessary, measures should be taken against use by unauthorised persons, the use by unskilled persons as well as persons not equipped with a complete fall protection system, a „system to secure against unauthorised access“ as described in Annex A must be used if this is attached to the vertical ladder.
In this case a written warning or a signal beep is not adequate means of access control.
- As a measure against falling, railings of at least 1500 mm in length are to be provided as follows:
 - from the vertical axis of the ladder on both sides;
 - over the entire length of the edge, if the length on both sides is less than 1500 mm (therefore the total length of the edge is less than 3000 mm).
- Ladders with a clear width < 400 mm (up to a clear width of 300 mm) are only permitted in accordance with DIN 14122-4 if the immediate surroundings do not allow larger rungs and no alternative installation location is possible.
- The space between the vertical ladder and the surrounding area must be 650 mm from the front edge of the ladder rung (600 mm in the case of obstructions). Access openings must be at least equivalent to the area enclosed by the back guard system.

DIN 14094-1:2017-04

- Emergency ladder systems may only be used as an escape route and must be kept clear at all times.
- The customer must check the substrate for sufficient carrying capacity during the planning phase! Proof of the required carrying capacity and of appropriate installation must be provided individually for each building project and must be checked and inspected by a responsible expert for stability.
- The responsible fire protection service must be involved in the planning of emergency ladder systems.
- Fixed vertical ladders are to be arranged at an angle of inclination of more than 75° to 90° to the horizontal.
- Access control systems can be used if the vertical ladder ends in a location accessible by the public.
- Sufficient dimensioning, number and material for the anchors provided for fastening must be determined and specified during planning. The suitability must be verified by a certificate of usability or must be explicitly proven.

5. Warranty and Liability

The safety notes and regulations must be followed to ensure an error-free installation and use of the fixed ladder.

This installation and operating manual should be read by anyone who installs and uses the fixed ladder.

Furthermore, the applicable on-site regulations on accident prevention must be followed.

There is no liability for material or personal damage as a result from the following reasons:

- Improper installation and use of the fixed ladder.
- Unintended use of the fixed ladder system.
- Use of the fixed ladder despite safety deficiencies.
- Ignorance or non-observance of this installation and operating manual.
- Unauthorized changes to the fixed ladder system.*
- Use of non-genuine spare parts.
- Insufficiently qualified or insufficiently instructed installation and operating personnel.

* Structural modifications to the vertical ladder system are only permitted if the following conditions are met:

- The ladder is shortened at the bottom end while complying with the specified measurements (see page 15),
- The vertical bars are shortened while complying with the installation instructions (see pages 34 and 35).

The following requirements are to be met at all times:

- The cut edges must be free of burrs,
- The cut edges on galvanised steel components must be refinished (DIN EN ISO 1461 – 6.3 “Reinstatement”, e.g. by applying a suitable zinc dust coating).

6. System Description

6.1 Overview of System Components

All illustrations are examples and may vary depending on the version used.

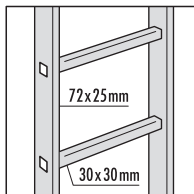

Aluminium ladder

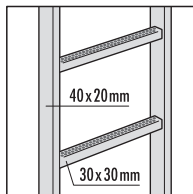

Steel ladder
Stainless steel ladder

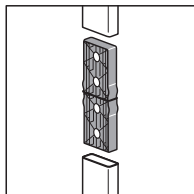

Ladder connector
(internal connector),
Aluminium-ladder

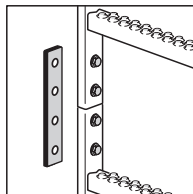

Ladder connector
(internal connector),
Steel/stainless steel ladder

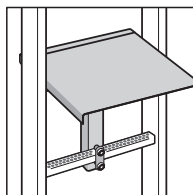

Rest platform

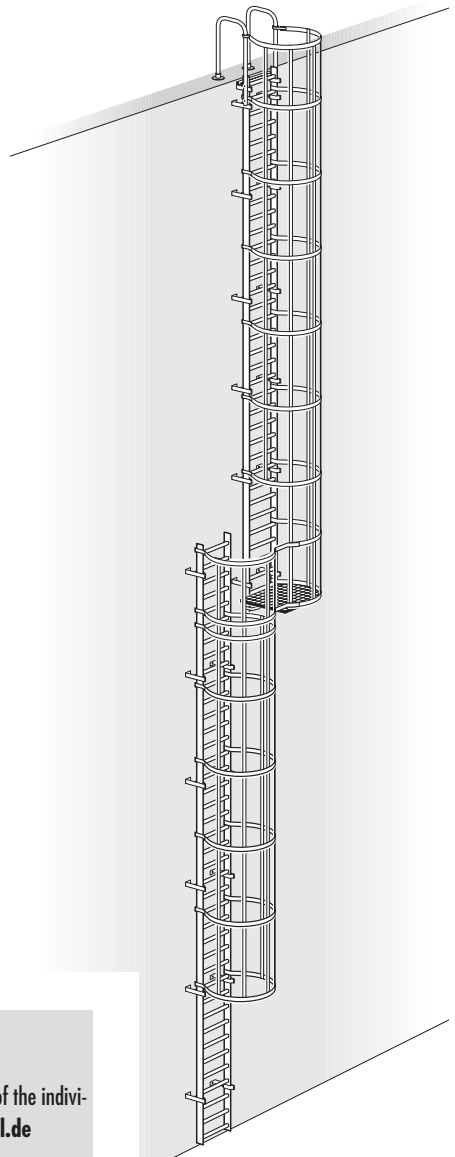

Further information regarding design and article numbers of the individual products can be found at: www.hailo-professional.de

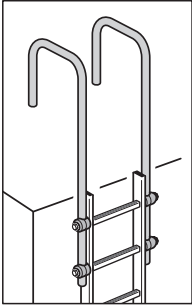

Exit rail
(various types)

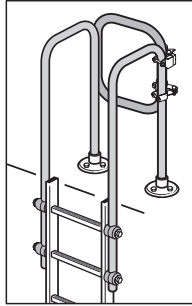

Long exit rail
(with a safety barrier)

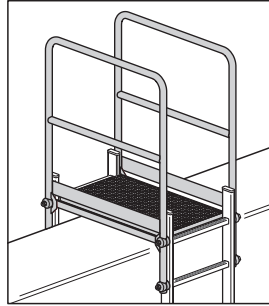

Crossing platform

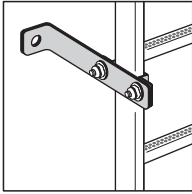

Standard
wall bracket

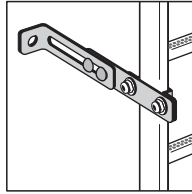

Adjustable
wall bracket

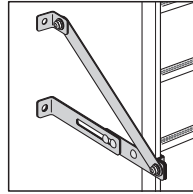

Special wall bracket
and suspension rod

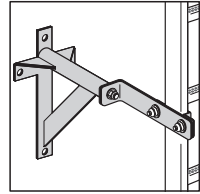

Wall bracket
with substructure

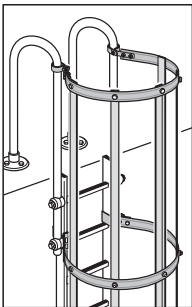

Back-guard system

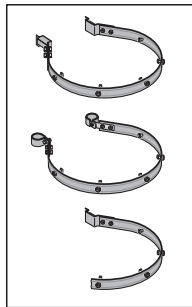

Back-guard hoops

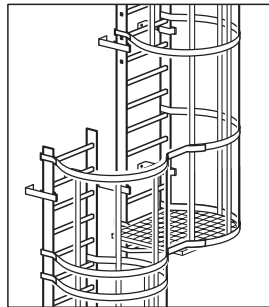

Back-guard system
(system components)

6. System Description

6.2 System Visualisation (General Requirements)

- According to DIN 18799-1 and DIN 14094-1 fixed vertical ladders are to be arranged at an angle of inclination of more than 75° to 90° to the horizontal.
- According to DIN 18799-1 and DIN EN ISO 14122-4 fall protection is required for heights ≥ 3m.
- According to DIN 14094-1 only back-guard is allowed.
- The uppermost wall bracket should be installed max. 560 mm (corresponding to 3 ladder rungs) below the exit point.

A) Single section ladder, basic unit without back-guard	DIN 18799-1, DIN EN ISO 14122-4
B) Single section ladder, basic unit with back-guard	DIN 18799-1, DIN EN ISO 14122-4, DIN 14094-1
C) Multi-sectional ladder with back-guard	DIN EN ISO 14122-4, DIN 14094-1
D) Multi-sectional ladder with back-guard	DIN 18799-1

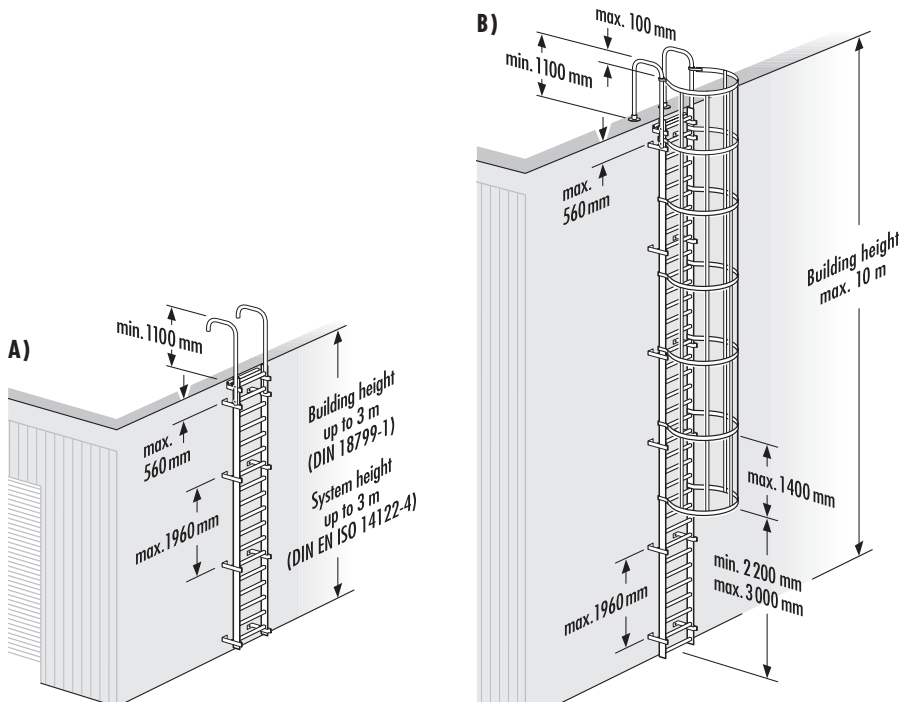

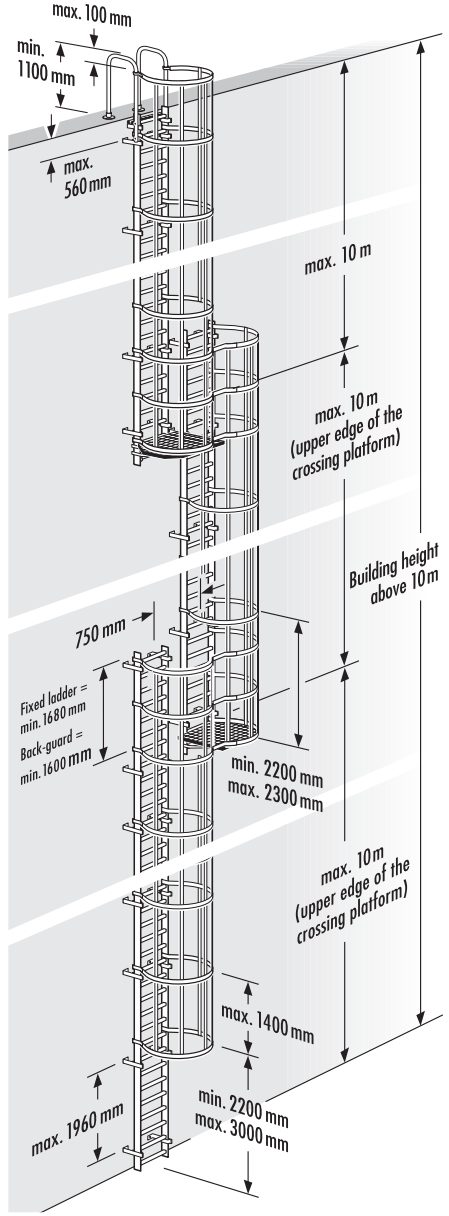
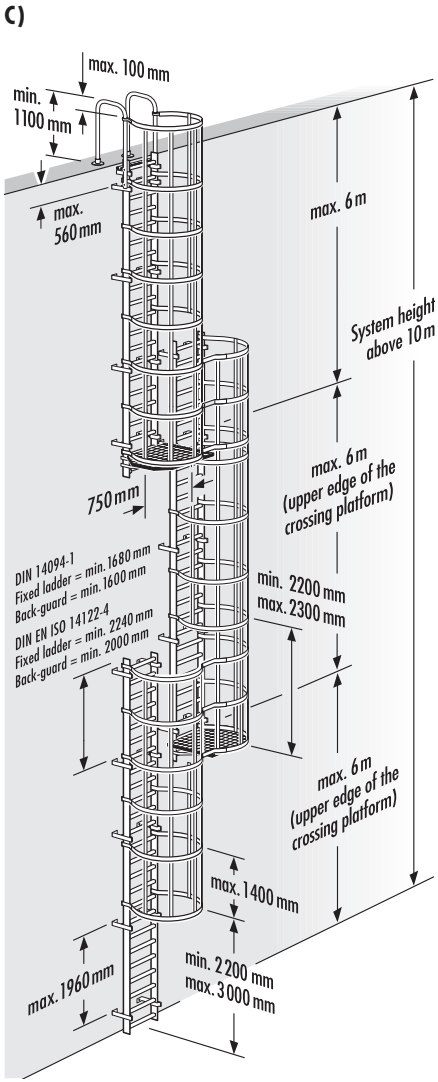

7. General Installation Instructions

7.1 Preliminary Notes

- Before installation, make sure that the loads can be absorbed by the wall.
- If there is no information available on this (documents), then a static certificate of approval, that includes the required load capacity, is mandatory.
- If Hailo's special wall brackets are used, then they must be mounted according to the instructions in the relevant drawings, static or other specifications.

The loads stated on page 18 - 23 apply only to Hailo's standard wall bracket.

- If the necessary proof (for a safe load consumption) is not provided, then in case of damage the manufacturer cannot be made responsible for product liabilities. The liability is then passed on to the operator.

Installation personnel

- Installation personnel for the fixed ladder system must be appropriately qualified and competent. Training may be necessary from the manufacturer for the use of required fasteners.
- The installation personnel must not fasten themselves to the system that is being installed.
- They must use an approved attachment point on the wall according to EN 795 or another construction.

Installation

- Only use clean and undamaged system-parts.
- Damaged parts must be replaced with new parts.

Installation protocol

- The installation of the ladder system is to be fully documented by the technical supervisor of the installation company.



Caution: risk of falling!

During installation use an arrester system as specified in EN 363.

Installation of the fixed ladder (specified dimensions)

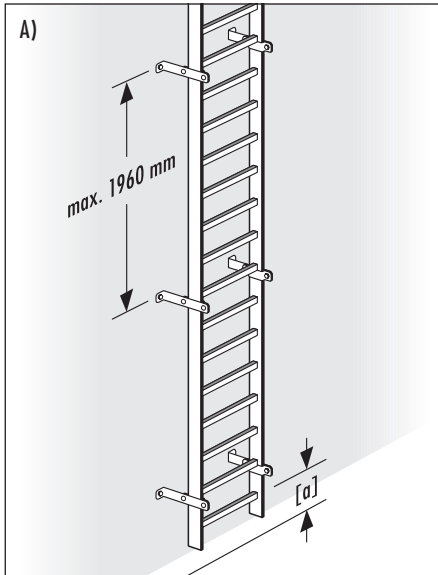

Figure A)

For the spacing dimension [a] the following principles apply:

DIN EN ISO 14122-4:

[a] = max. 300 mm, min. 225 mm.

DIN 18799-1 and DIN 14094-1:

[a] = max. 400 mm, min. 100 mm.

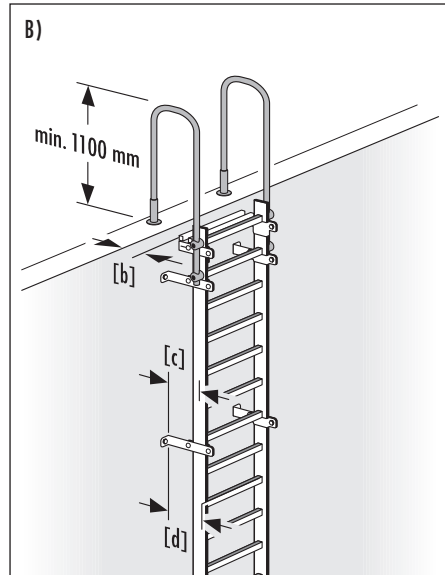

Figure B)

The top rung of the ladder of an exit extension must be at the same height of the exit point.

[b] = the exit extension must not exceed the max. distance of 75 mm away from the wall.

[c] = the distance of the ladder (middle of the rung) to the mounting surface is at least 185 mm (Hailo).

[d] = the distance of the ladder (front edge of the rung) to the mounting surface must be at least 200 mm (DIN EN ISO 14122-4, DIN 18799-1, DIN 14094-1).

7. General Installation Instructions

7.2 Installation Instructions

Instructions for mounting to the building:

- The attachment points and their connections (brackets, fasteners) must be able to absorb the loads.
- When sizing the ladder-fixture and attachment points a load of at least 3 kN per side rail and 6 kN per ladder is to be considered.
This load must be transferred to the structure via at least 4 attachment points per ladder.
This is the equivalent of 1.5 kN per attachment point.
- The attachment points must not exceed a vertical distance of max. 1960 mm (this corresponds to 7 rungs with a rung spacing of 280 mm).
- The attachment points must always be in pairs, to the right and left of the ladder and arranged at the same level.
- The base surface of the structure must be sufficiently dimensioned and suitable for the previously mentioned loads.
- Suitable base surfaces are:
 - steel constructions
 - with threaded bushings, min. M12 (see figure A),
 - through-bolt connections,
 - concrete buildings
 - anchor dowel fixings to concrete buildings (see figure B).

Mounting to concrete structures:

- For concrete structures only building authority approved dowels may be used.
- A minimum concrete quality of B20/25 is required when using a back guard system and C30/37 when using a fall protection system.

Mounting to masonry structures:

- For masonry structures only building authority approved dowels may be used.
- For non-defined surfaces, the fastening system must be consulted with the structural engineers.
- An anchor-bolt with counter-plate is also conceivable. This is to be coordinated with the planner and must be certified.



Before mounting the ladder, make sure that the load transfer to the supporting structure can be guaranteed with a sufficient degree of security (to be coordinated with the planner)!

Pay attention to the installation instructions of the dowel manufacturer!

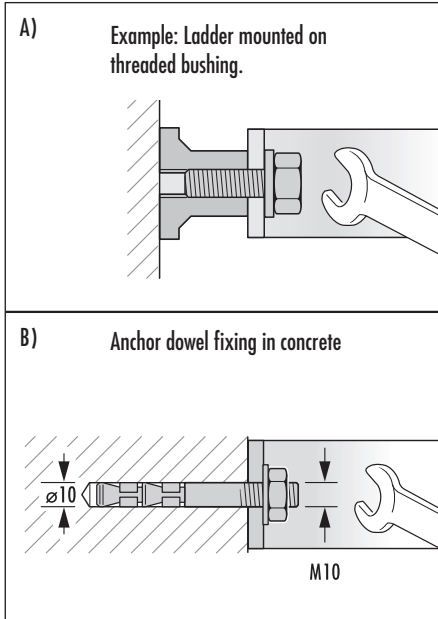

Tightening torques for the bolts

- Bolted connection with steel screws:

max. tightening torque M_A (Nm) with a total friction coefficient $\mu = 0.08$ ($\mu = 0.08$ is equivalent to a galvanized, uncoiled, dry surface)

Strength class 8.8: Strength class 10.9:

M 8 = 17.9 Nm

M 8 = 26.2 Nm

M 10 = 36.0 Nm

M 10 = 53.0 Nm

M 12 = 61.0 Nm

M 12 = 90.0 Nm

M 16 = 147.0 Nm

M 16 = 216.0 Nm

M 20 = 297.0 Nm

M 20 = 423.0 Nm

- Bolted connection with stainless steel bolts A2 + A4:

max. tightening torque M_A (Nm) with a total friction coefficient $\mu = 0.10$ ($\mu = 0.10$ is equivalent to an uncoiled, dry surface)

Strength class 70:

M 8 = 14.5 Nm

M 10 = 30.0 Nm

M 12 = 50.0 Nm

M 16 = 121.0 Nm

M 20 = 244.0 Nm

Strength class 70 is the equivalent to a cold-press manufacturing up to a nominal length of $8 \times d$ and at a yield strength of $R_p 0.2 = 90\%$.

7. General Installation Instructions

7.3 Load Scheme Standard Wall Brackets

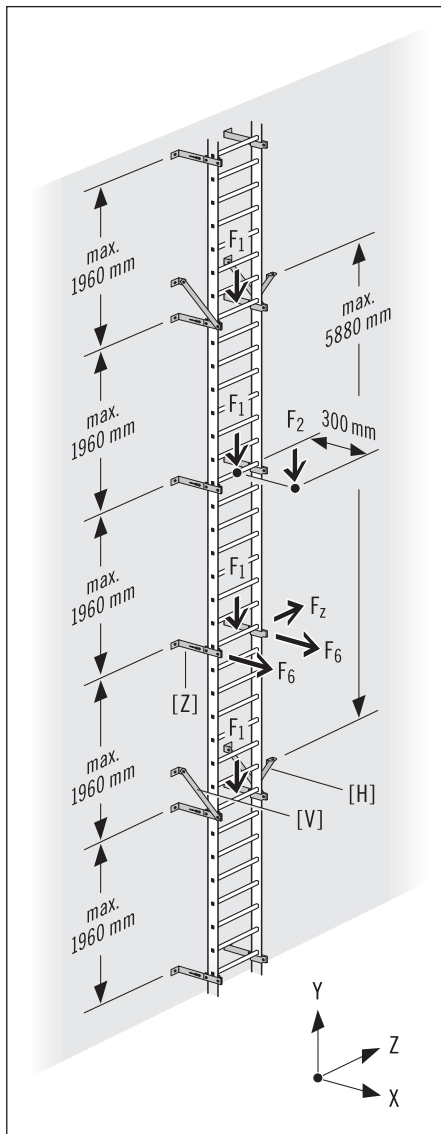

F_1 = Assumption: 4 people are on the ladder at the same time each with 1.5 kN man load.

F_2 = Eccentric acting man load.

The following requirements apply to the pull-out forces specified:

1. Ladder with fall arrest system:

For any ladder length and max. 5 persons at a distance of min. 6 metres on the ladder.

Ladder with back-guard system:

For a ladder length of 10 metres and one person 2 metres apart on the ladder respectively.

2. With a wall clearance > 215 mm, a wall bracket with vertical strut [V] is required every 5880 mm.

With a wall clearance > 300 mm, a wall bracket with vertical strut [V] and horizontal strut [H] is required every 5880 mm.

Intermediate brackets [Z] (max. 1960 mm spacing) do not require vertical or horizontal struts.

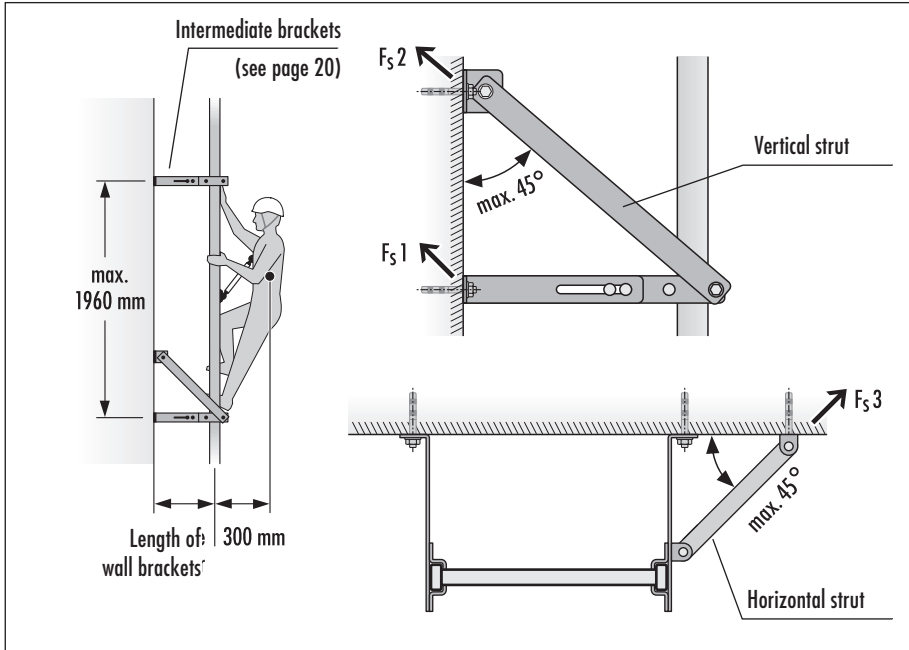

	Load specifications (typical values in kN per anchor)		
	Total inclined tensile load for wall brackets F _{S1}	Total inclined tensile load for V struts F _{S2}	Total inclined tensile load for H struts F _{S3}
Adjustable wall bracket Max. distance of the wall bracket = 5880 mm			
Adjustable wall bracket 185 - 300 mm (with vertical struts)	0,96 kN * 1,41 kN **	3,16 kN * 4,08 kN **	no H struts
Adjustable wall bracket 300 - 430 mm (with vertical and horizontal struts)	0,92 kN * 1,35 kN **	3,16 kN * 4,08 kN **	0,87 kN

* = mit back-guard system, ** = with fall arrest system

7. General Installation Instructions

7.3 Load Scheme Standard Wall Brackets

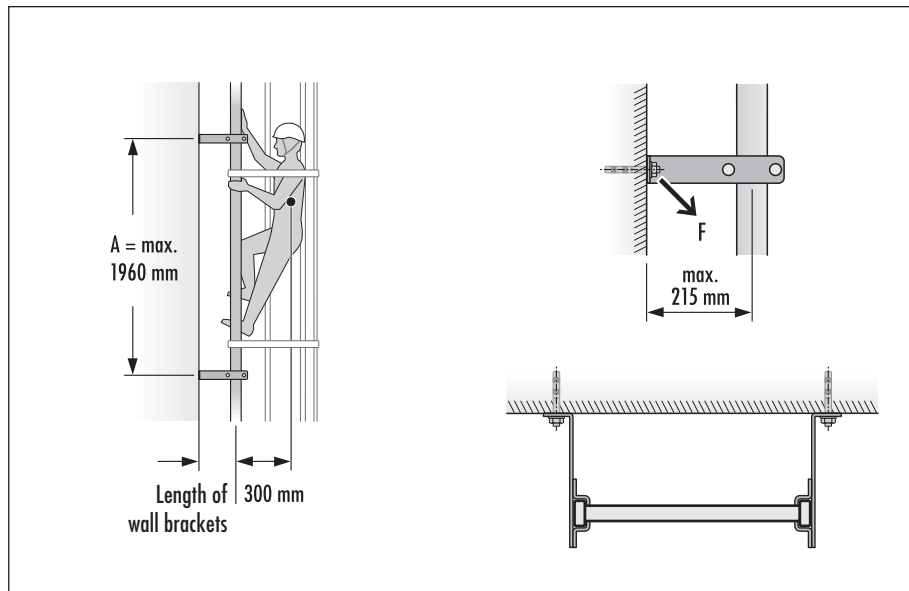

Ladder with back-guard system

Wall bracket max. 1960 mm horizontal distance		Load specifications (typical values in kN per anchor)
		Total inclined tensile load for wall brackets F
Standard wall bracket	185 mm	3,40 kN
Adjustable wall bracket	185 - 215 mm (width = 75 mm)	2,82 kN
Adjustable wall bracket	185 - 300 mm	0,96 kN
Adjustable wall bracket	300 - 430 mm	0,92 kN
(only to be used as intermediate brackets for adjustable wall brackets with horizontal and/or vertical struts)		

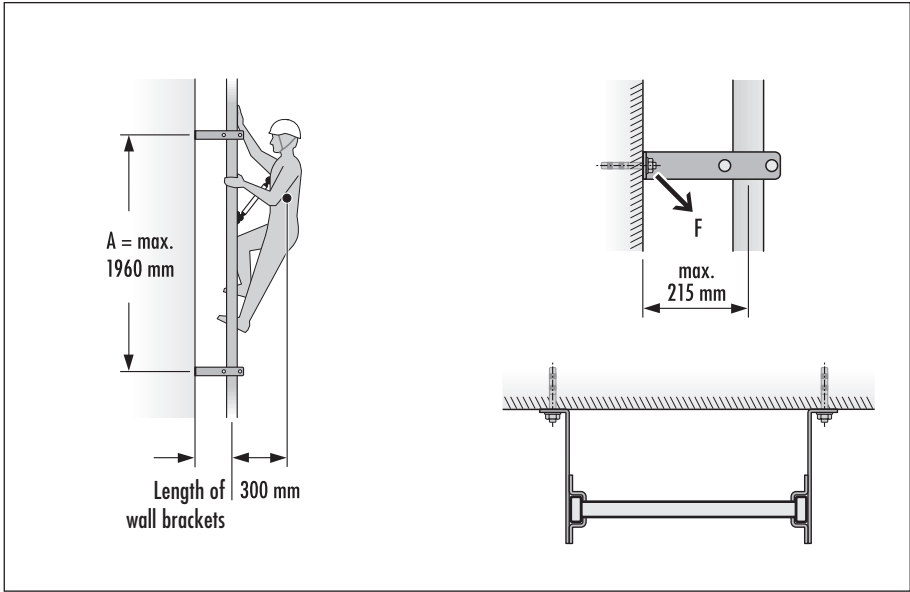

Ladder with fall arrest system

Wall bracket max. 1960 mm horizontal distance		Load specifications (typical values in kN per anchor)
		Total inclined tensile load for wall brackets F
Standard wall bracket	185 mm	4,99 kN
Adjustable wall bracket	185 - 215 mm (width = 75 mm)	4,14 kN
Adjustable wall bracket	185 - 300 mm	1,41 kN
Adjustable wall bracket	300 - 430 mm	1,35 kN
(only to be used as intermediate brackets for adjustable wall brackets with horizontal and/or vertical struts)		

7. General Installation Instructions

7.4.1 Load Scheme Standard Wall Brackets and Substructure - Version 1 (OLD)

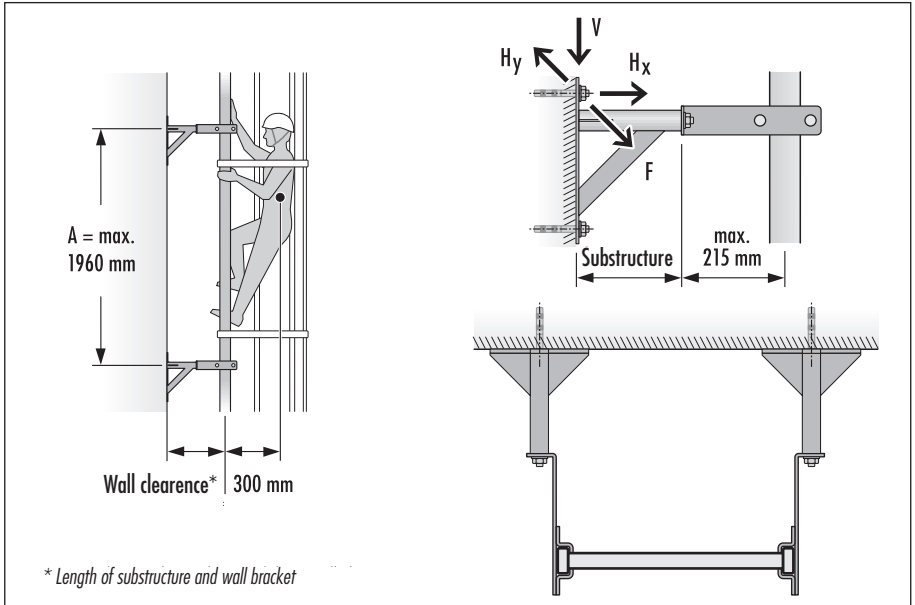

Ladder with back-guard system

Substructure (all lengths) Distance between wall brackets = A	Load specifications			
	Total inclined tensile load for wall brackets F	V	H _x	H _y
A = 1960 mm	1,14 kN	0,45 kN	1,14 kN	0,15 kN
A = 1680 mm	1,02 kN	0,41 kN	1,02 kN	0,13 kN
A = 1400 mm	0,98 kN	0,38 kN	0,98 kN	0,11 kN
A = 1120 mm	0,97 kN	0,36 kN	0,97 kN	0,08 kN
A = 840 mm	0,97 kN	0,34 kN	0,97 kN	0,06 kN

Minimum number of wall brackets per ladder = 8 brackets (4 brackets per ladder stile, arranged in pairs).

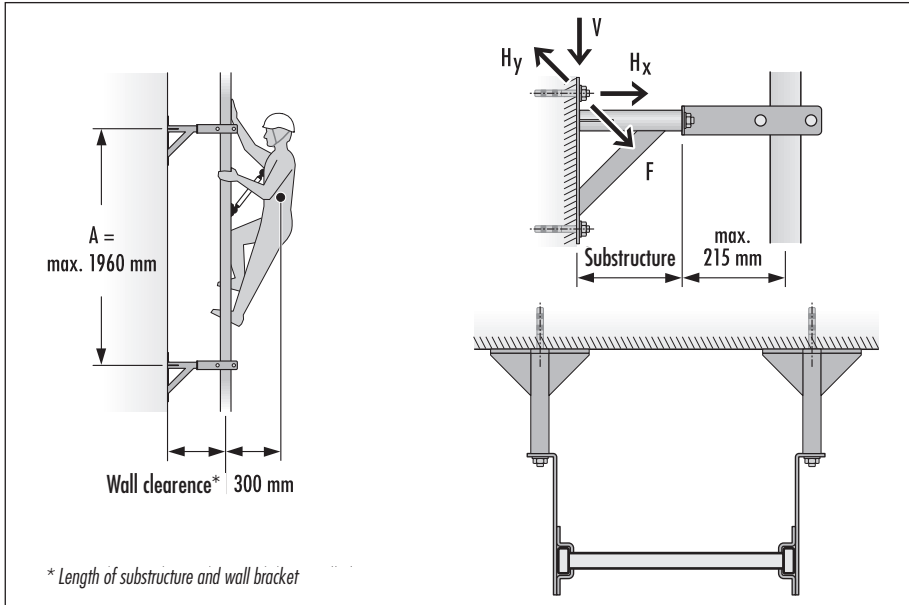

Ladder with fall arrest system

	Load specifications			
	Maximum pull-out strength of maximum tension anchor bolt per ladder bracket Length of ladder = without restrictions			
Substructure (all lengths) Distance between wall brackets = A	Total inclined tensile load for wall brackets F	V	H _x	H _y
A = 1960 mm	1,51 kN	0,47 kN	1,43 kN	0,15 kN

Minimum number of wall brackets per ladder = 8 brackets (4 brackets per ladder stile, arranged in pairs).

7. General Installation Instructions

7.4.2 Load Scheme Standard Wall Brackets and Substructure - Version 2 (NEW)

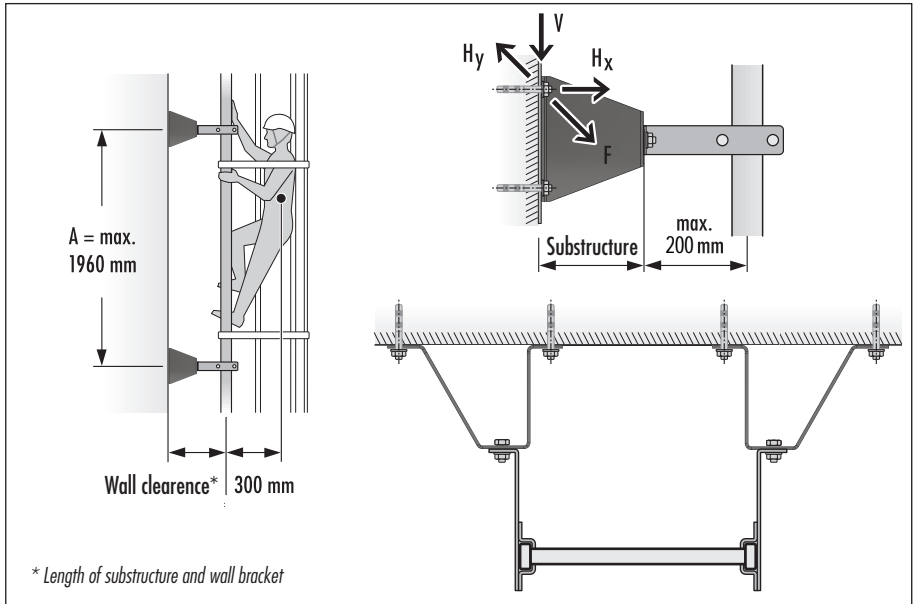

Ladder with back-guard system

Substructure (all lengths) Distance between wall brackets = A	Load specifications			
	Total inclined tensile load for wall brackets F	V	H _x	H _y
A = 1960 mm	1,38 kN	0,84 kN	1,09 kN	0,15 kN
A = 1680 mm	1,24 kN	0,72 kN	1,00 kN	0,13 kN
A = 1400 mm	1,15 kN	0,60 kN	0,97 kN	0,11 kN
A = 1120 mm	1,06 kN	0,48 kN	0,94 kN	0,08 kN
A = 840 mm	1,00 kN	0,36 kN	0,92 kN	0,06 kN

Minimum number of wall brackets per ladder = 8 brackets (4 brackets per ladder stile, arranged in pairs).

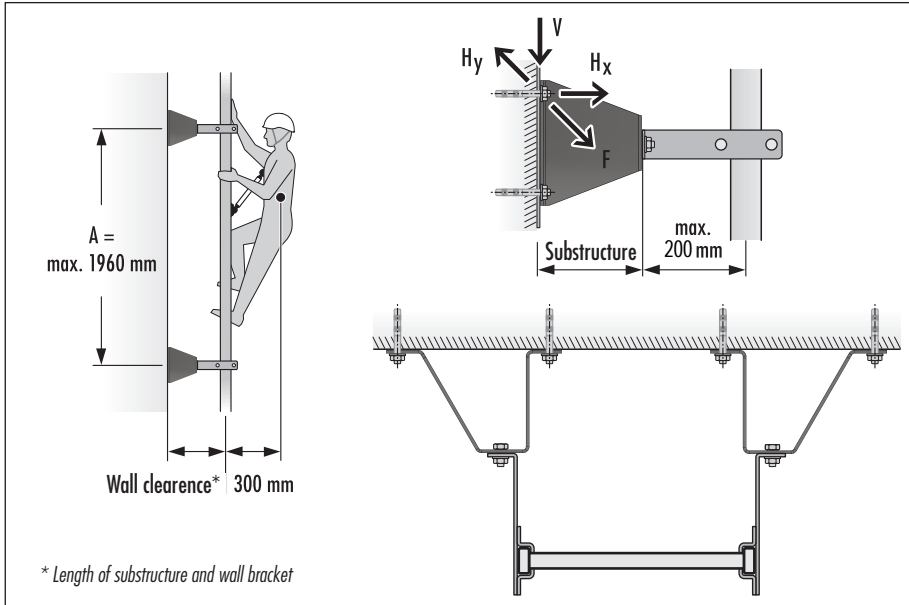

Ladder with fall arrest system

	Load specifications			
	Maximum pull-out strength of maximum tension anchor bolt per ladder bracket Length of ladder = without restrictions			
Substructure (all lengths) Distance between wall brackets = A	Total inclined tensile load for wall brackets F	V	H _x	H _y
A = 1960 mm	1,38 kN	0,84 kN	1,09 kN	0,15 kN

Minimum number of wall brackets per ladder = 8 brackets (4 brackets per ladder stile, arranged in pairs).

8. Mounting the Fixed Ladder

8.1 Installation Examples: Various Wall Bracket Versions

Consider the minimum exit depth:

The distance of the ladder (front edge of the rung) to the mounting surface must be at least 200 mm (DIN EN ISO 14122-4, DIN 18799-1, DIN 14094-1).

- A) Mounting the ladder with standard wall brackets and rail brackets.
- B) Mounting the ladder with adjustable wall brackets (185 - 215 mm) and rail brackets.
- C) Mounting the ladder with adjustable wall brackets (185 - 300 mm) and rail brackets.
- D) Assembly of vertical ladder with tie rod set for wall brackets (300 - 430 mm) and clamps for uprights plus additional side support.

For distances between rung and building ≥ 300 mm additional tie rods (each on the right and left of the ladder) are required, that must be attached at a vertical distance of max. 5880 mm.

All illustrations are examples and may vary depending on the version used.

M 10	ST	$M_A = 20 \text{ Nm}$
	VA	$M_A = 18 \text{ Nm}$

Assembly note:

M = Metric thread, \varnothing

ST = Steel

VA = Stainless steel

M_A = Tightening torque (Nm)

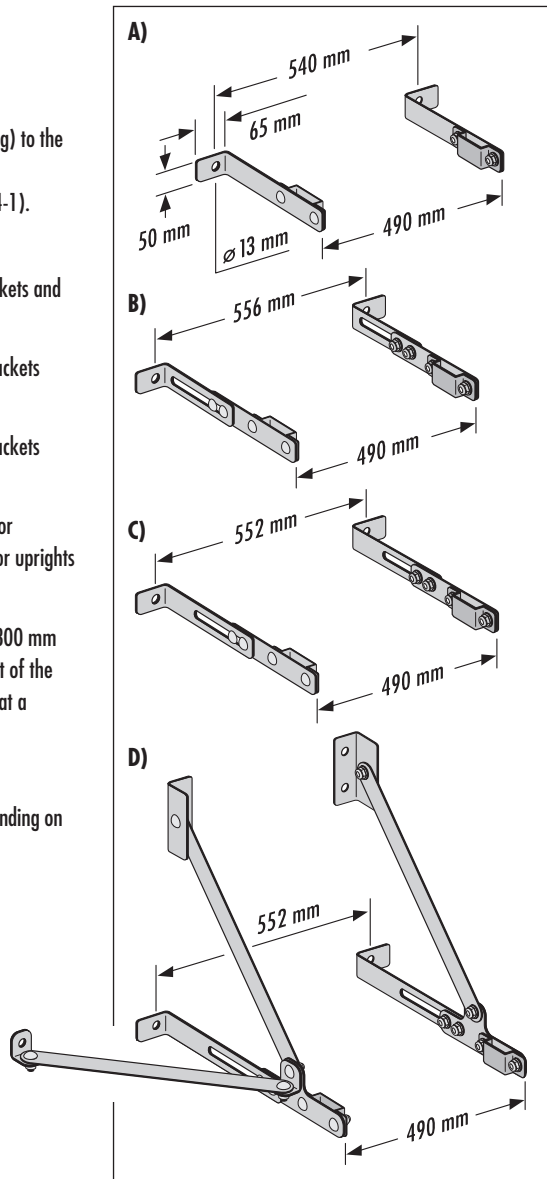

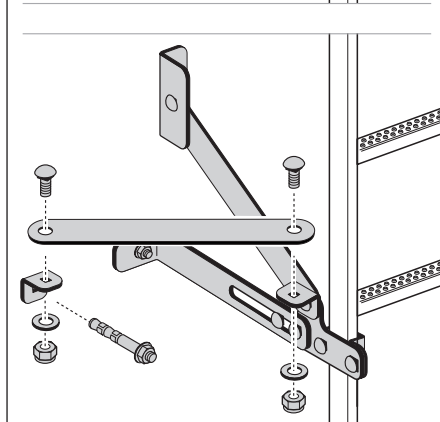
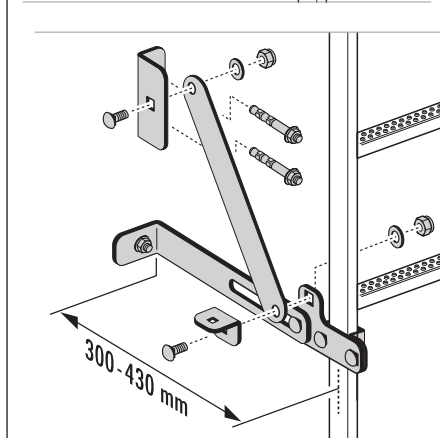
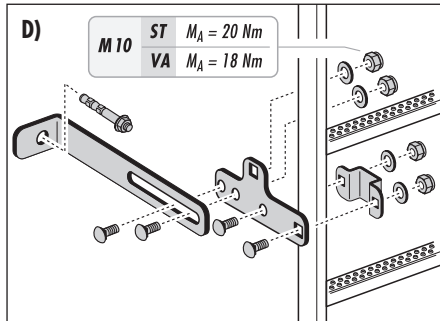
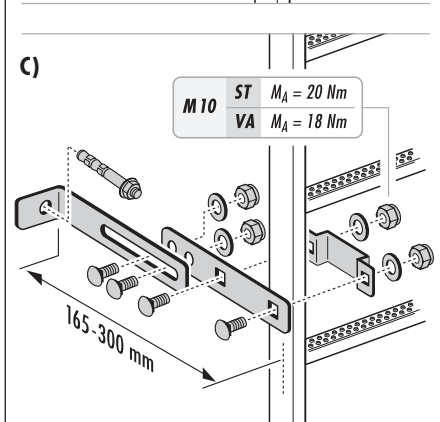
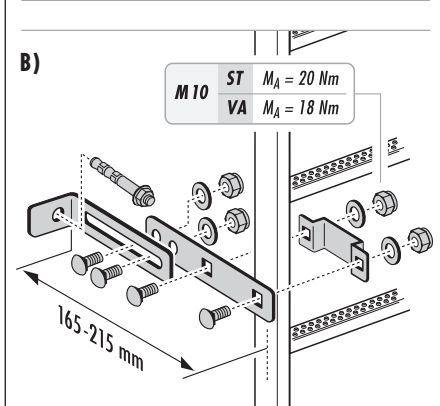
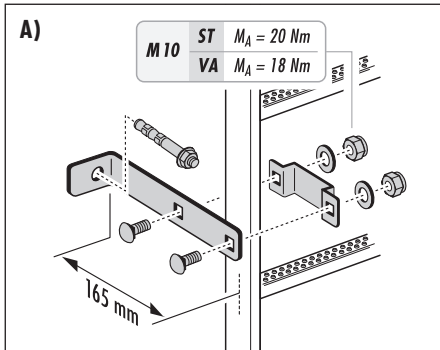

8. Mounting the Fixed Ladder

8.1.1 Installation Examples: Various Wall Bracket Versions Version 1 (OLD)

E) Substructures for wall brackets

Application:

- Used for thermal insulation composite systems on facades
- Used where there are larger distances between the structure/plant and the fixed vertical ladder.

A standard wall bracket (185 mm) with clamps for uprights [A] is always used as an example in the illustrations.

F) Installation of the vertical ladder with substructure for wall brackets and standard wall brackets with clamps for uprights.

Max. length of standard wall bracket = 215 mm.

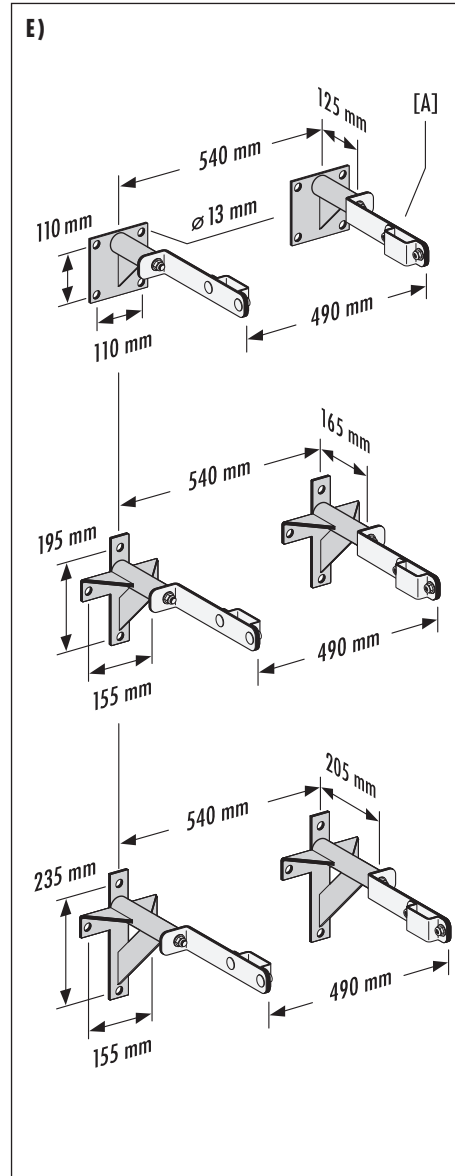

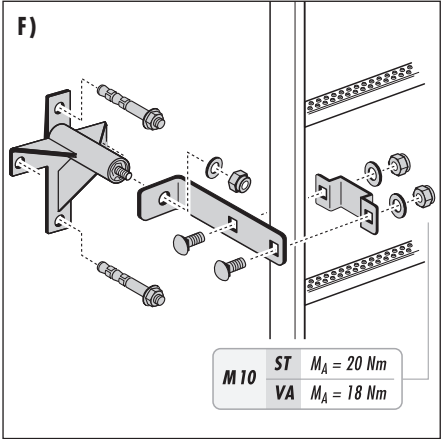
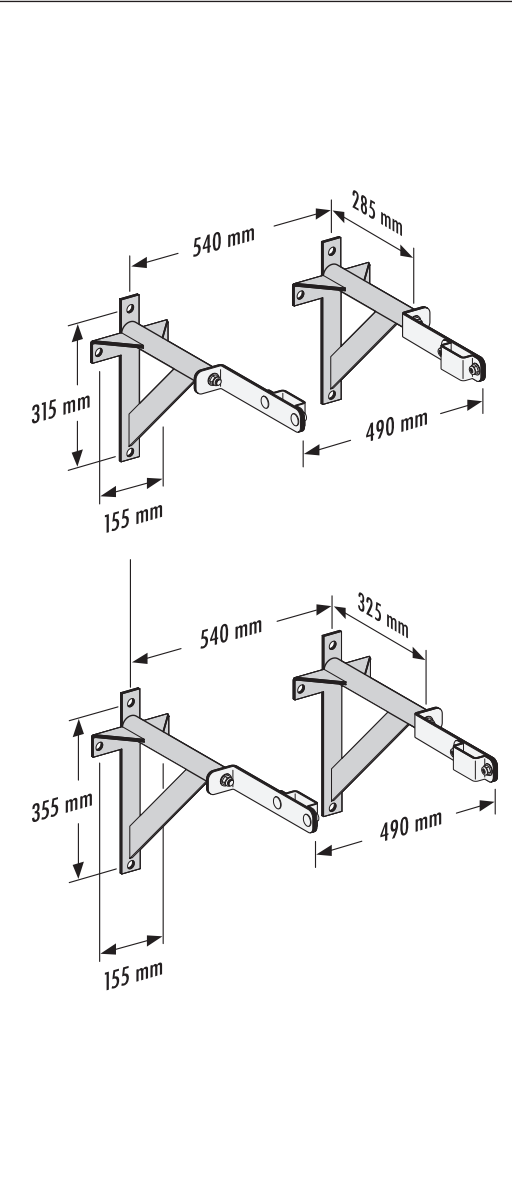

8. Mounting the Fixed Ladder

8.1.2 Installation Examples: Various Wall Bracket Versions Version 2 (NEW)

E) Substructures for wall brackets

Application:

- Used for thermal insulation composite systems on facades
- Used where there are larger distances between the structure/plant and the fixed vertical ladder.

A standard wall bracket (185 mm) with clamps for uprights [A] is always used as an example in the illustrations.

F) Installation of the vertical ladder with substructure for wall brackets and standard wall brackets with clamps for uprights.

Max. length of standard wall bracket = 185 mm.

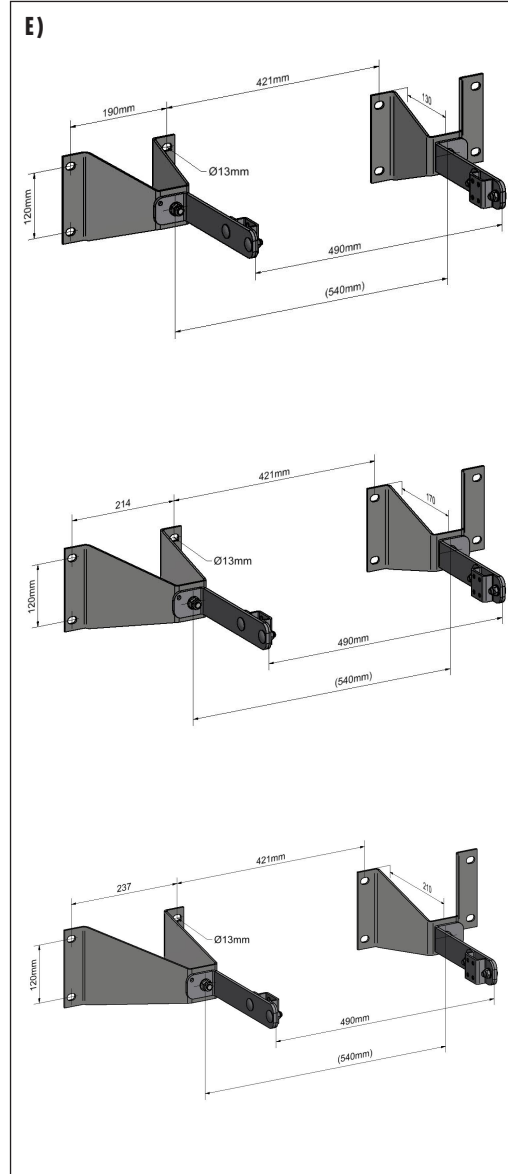

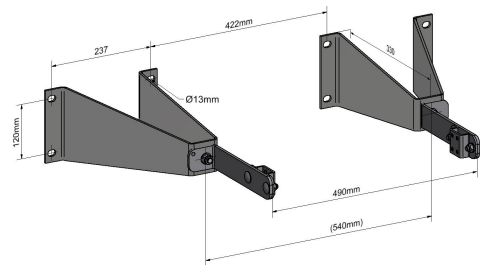
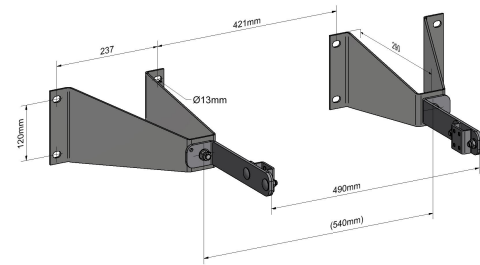
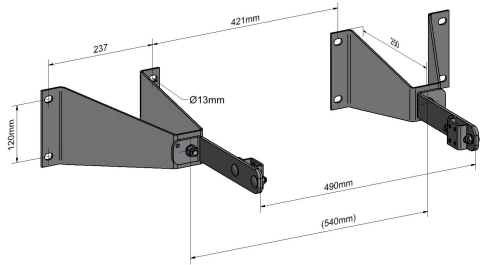

F)

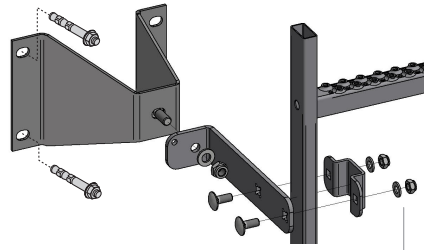

M 10	ST	$M_A = 20 \text{ Nm}$
	VA	$M_A = 18 \text{ Nm}$

8. Mounting the Fixed Ladder

8.2 Installation Examples:

Ladder Connection Components, Rung Repair

A) Internal rail connector

Material: plastic, can be inserted into the rail profile 72 x 25 mm.
The depth of the connector is limited by a middle bar. The rails are clamped accurately owing to the shape and surface of the rail connector. The press fitting prevents the internal rail connector from falling out of the ladder rail.

B) Internal rail connector

Material: metal, can be inserted into the rail profile 40 x 20 mm.
The ladder rails are bolted to the rail inside connectors as shown.

C) External rail connector

Material: stainless steel or galvanized steel,
for ladder rail 72 x 25 mm.

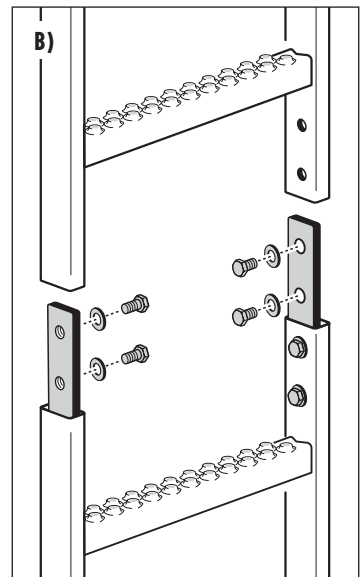
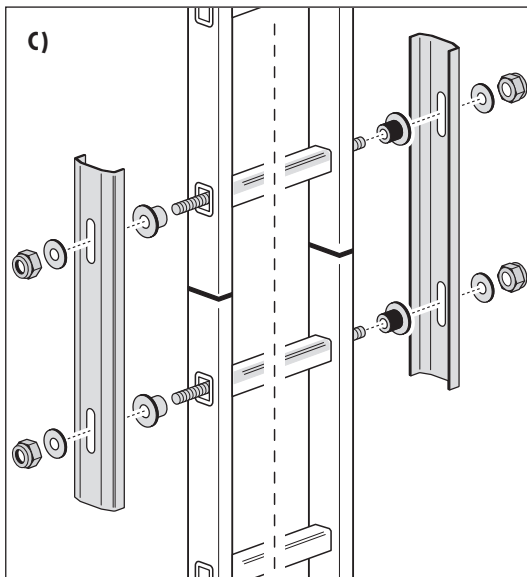
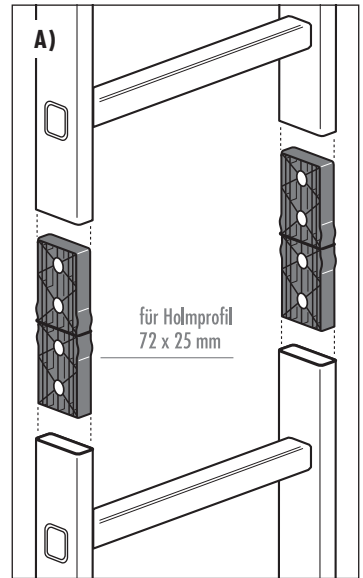

D) Section - external rail connector:

Material: stainless steel or galvanized steel, for ladder rail 72 x 25 mm.

With this external rail connector subsequent fitting or replacement fitting of ladder components is possible.

1. Fix the ladder ends to each other at the rail.
2. Plate 1 is used as a drill-template. Position plate 1 vertically and horizontally centred on the ladder rungs as shown and secure with two small clamps. Drill the ladder rail through the sleeves of the plate with a $\varnothing 10$ mm drill then remove the clamps and remove plate 1.
3. Drill the outer holes of the two ladder rails to $\varnothing 16.5$ mm.
4. Mount the external rail connector. Place plate 1 into the outer holes and screw it together with plate 2.

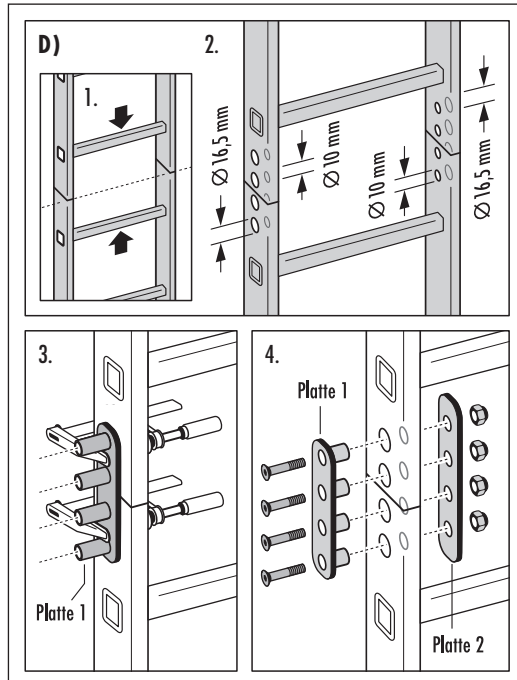

E) Rung repair kit

Material: galvanized steel, to be used when repairing.

Put the insertion piece into the ladder rung and then screw the rails together.

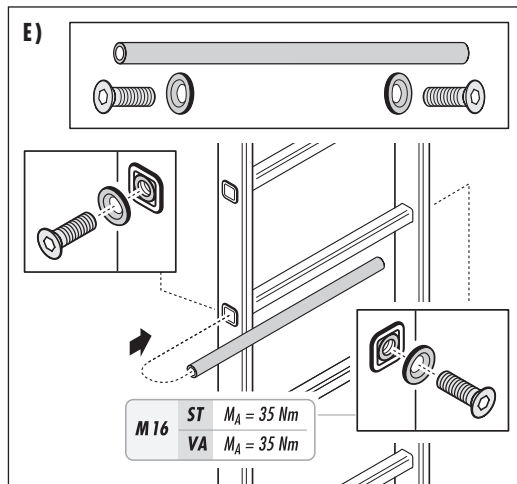

8. Mounting the Fixed Ladder

8.3 Installation Examples: Various Entrance / Exit Elements

Entrance / exit elements are generally used at the top / at the beginning of the climbing route on buildings as a crossing element.

A) Exit rail bracket straight

Material: stainless steel or galvanized steel.

B) Exit rail bracket short

Material: stainless steel or galvanized steel.

C) Exit rail bracket long

Material: stainless steel or galvanized steel.

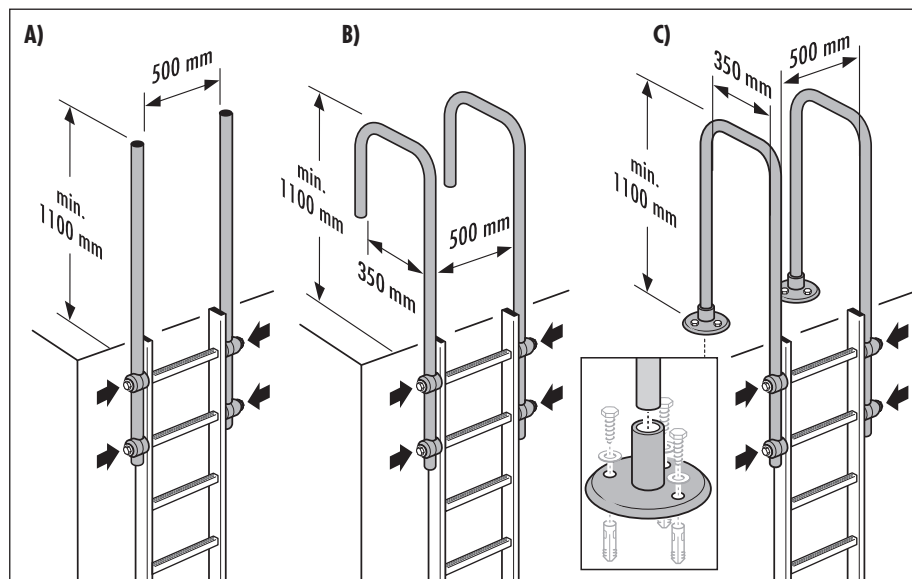
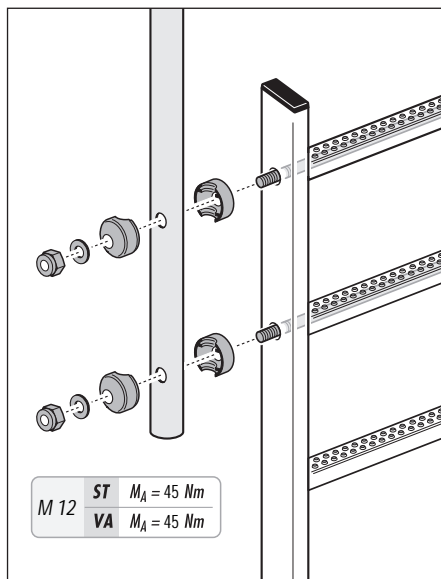

Exit rail bracket with safety barrier

- D)** Version including an additional security barrier simple (design does not comply with the standard).
- E)** Version including an additional security barrier with knee rail, 500 mm.
- F)** Version including an additional security barrier with knee rail, > 500 mm to 1000 mm.

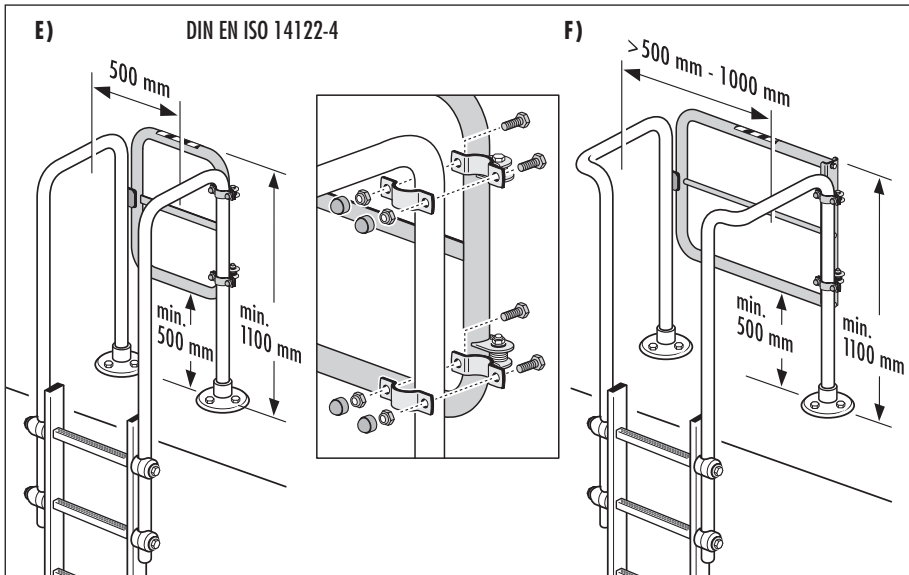
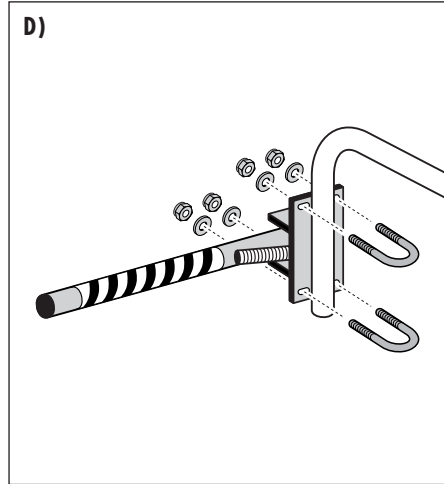

8. Mounting the Fixed Ladder

8.3 Installation Examples: Various Entrance / Exit Elements

G) Exit

Exit extension:
(max. distance to the wall = 75 mm).

for ladders with an outer width of 490 mm,
material: stainless steel or galvanized steel.

H) Crossing unit

Material: stainless steel or galvanized steel,
depth = 500 mm, 750 mm, 1000 mm, 1200 mm.

Different versions / sizes (customer specific)
are possible.

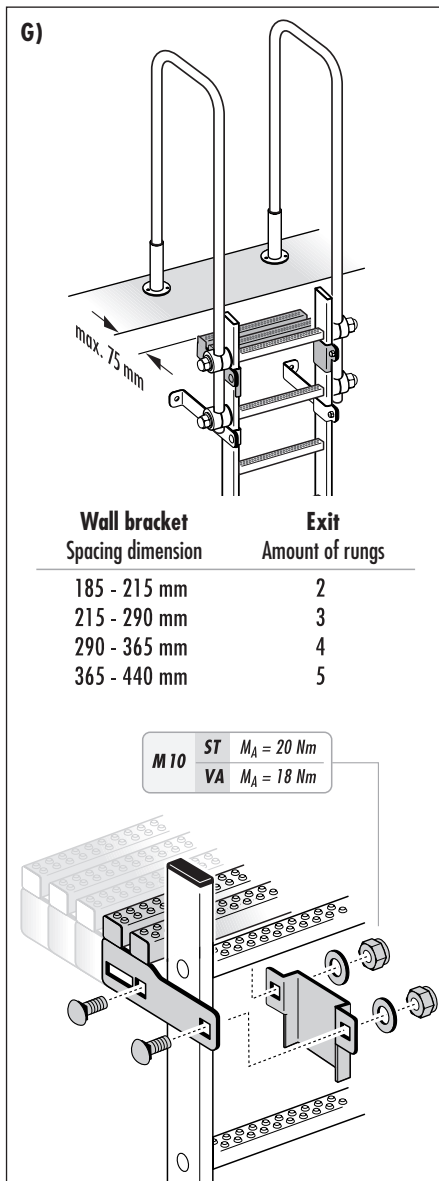

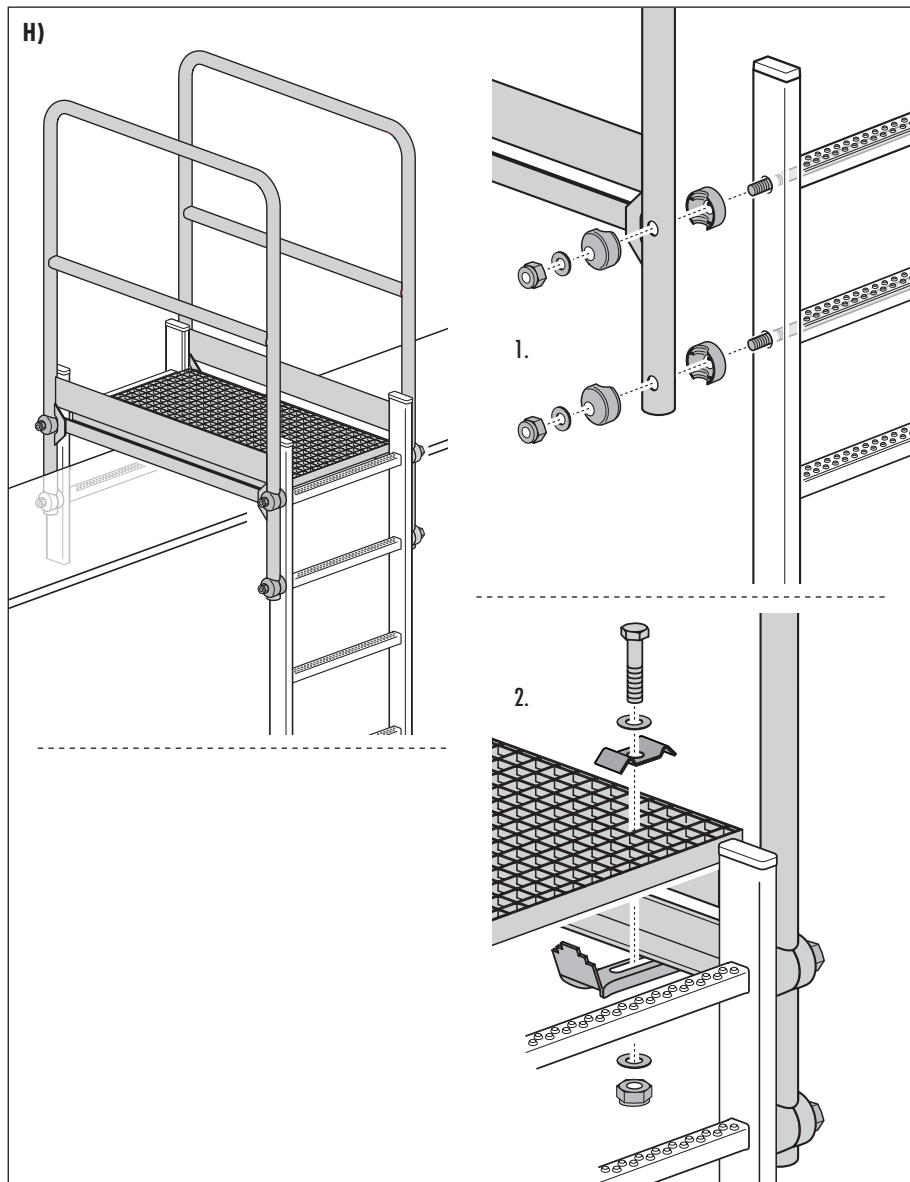

8. Mounting the Fixed Ladder

8.4 Installation Examples: Back Protection - System Components

Fall Protection / back-guard on ladders is necessary from a height of 3000 mm (EN ISO 14122-4, DIN 18799-1).

Material: stainless steel, galvanized steel or aluminium.

Assembly of the back-guard - basic elements

A) Assembly of the back-guard hoop

Fix the back-guard to the ladder rail.
Maximum distance between the back-guards on the ladder = 1400 mm.

B) Assembly of the vertical rods

1. Connect the vertical rods with the back-guard hoop.
2. When screwing the elements together, the correct position (x) of the slot-mark on the hammer head screw must be considered!

C) Assembly of the vertical rod connectors

1. Vertical rods are joined together with vertical rod connectors.
2. When screwing the elements together, the correct position (x) of the slit-mark on the hammer head screw must be considered!



During assembly, the hammer head screw must twist into the profile of the back-guard rod. Then a secure connection is guaranteed. Check the horizontal position of the slit mark on the hammer head screw (x)!

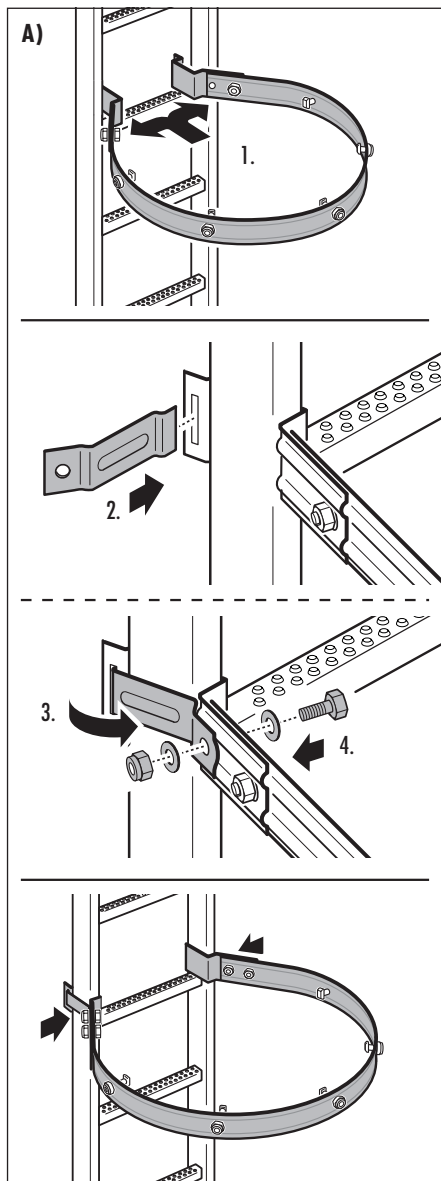

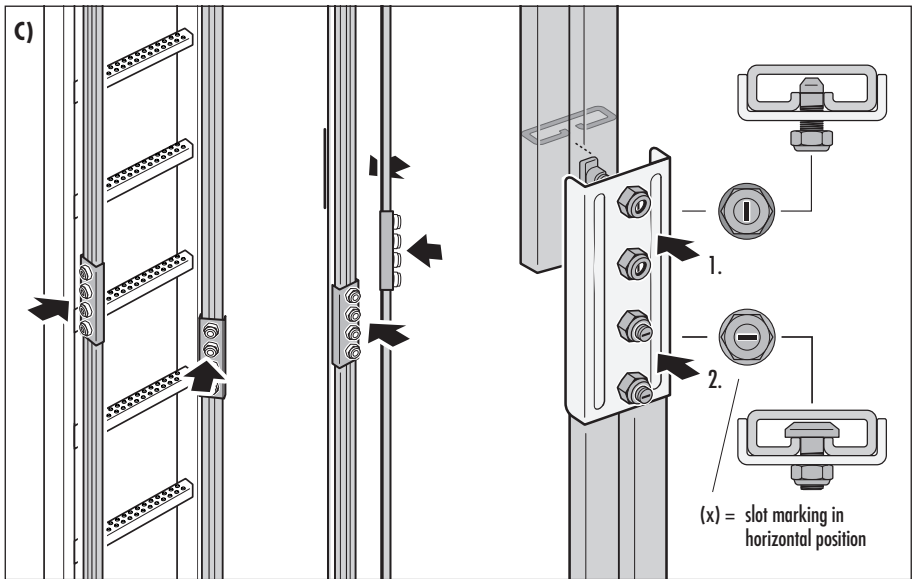
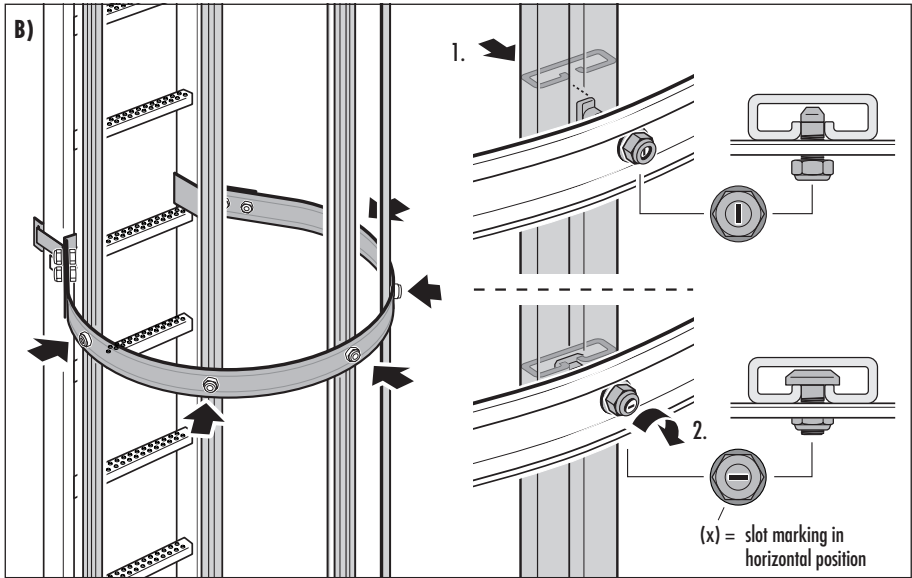

8. Mounting the Fixed Ladder

8.4 Installation Examples: Back Protection - System Components

Assembly of entrance and exit components;
installation of crossing elements for multiple ladders

D) Crossing elements

Fixing the two $\frac{3}{4}$ back-guard hoops to the crossing element.

E) Assembly of the crossing platform

1. Mount the holding brackets on both ladder rails.
2. Mount the crossing platform on the holding brackets.

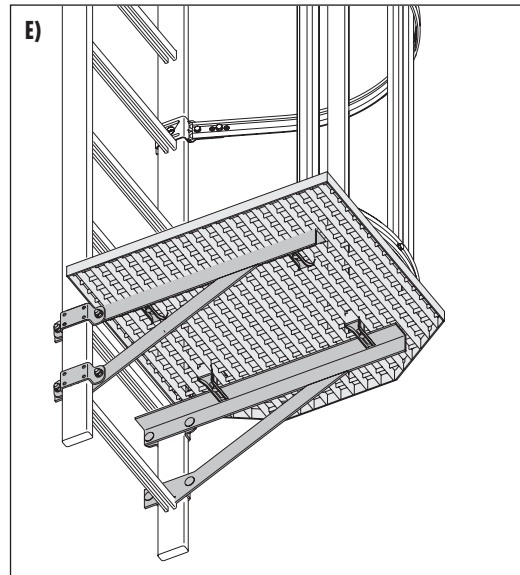
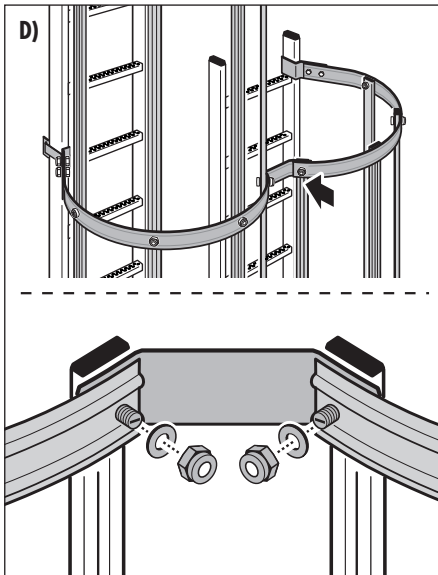

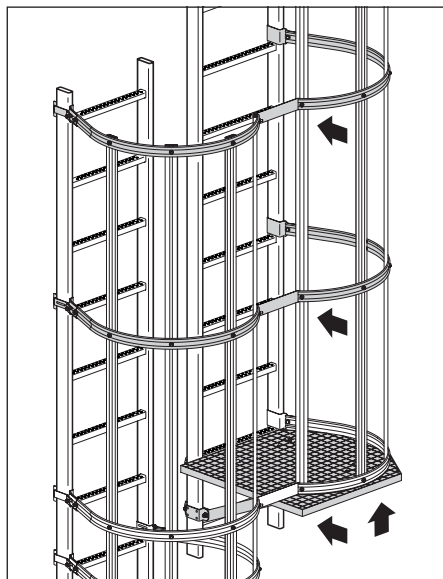

1.

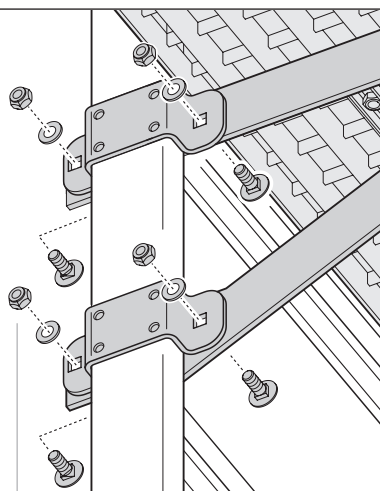

M 10	ST	$M_A = 20 \text{ Nm}$
	VA	$M_A = 18 \text{ Nm}$

2.

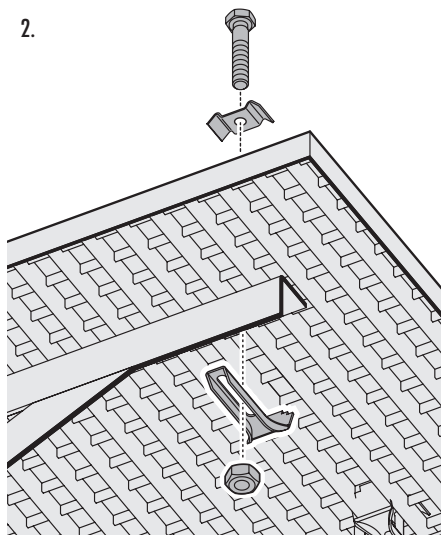

8. Mounting the Fixed Ladder

8.4 Installation Examples: Back Protection - System Components

Assembly of entrance and exit components;
installation of crossing elements for multiple ladders

F) Entrance-/Exit:

First of all mount the exit rail bracket (see 8.3 / entrance / exit components), then mount the back-guard hoops to the exit rail bracket.

G) Foldable rest seat

Follow the installation instructions on page 34/35 (back-guard hoops, and vertical rods).

1. First of all, mount the back-guard hoop to the ladder rail.
2. Mount the rest seat on the vertical rods.

The rest seat must lay firmly against the back-guard hoop when in resting position (grid is folded down).

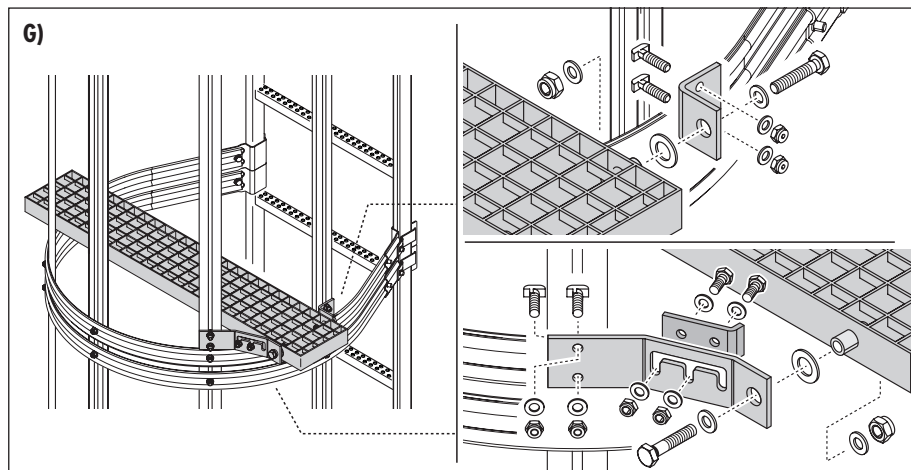
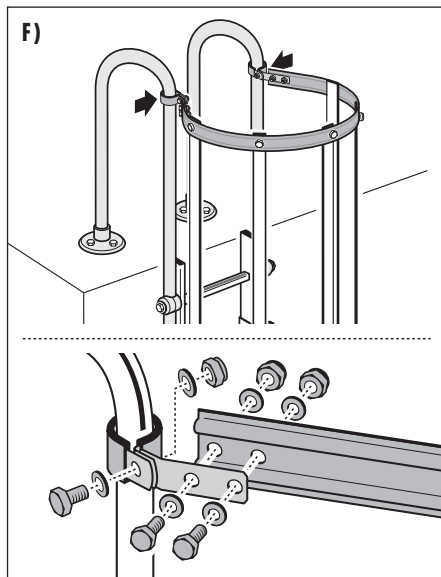

8.5 Installation Examples: Other System Components

A) Height-adjustable ground attachment

Material: stainless steel or galvanized steel.

B) Installation of a foldable resting platform

Installation of the foldable resting platform on the ladder rung
(Steel ladder, ladder inner measurement = 450 mm).

Note:
tighten the hexagon nut [X] just enough so that the foldable resting platform can be moved smoothly.

According to DIN 18799-1 for system heights ≥ 10 m a foldable rest platform must be installed at a height of max. 10m above the entrance level.

Every further 10 m a rest platform must be mounted to the ladder.

According to EN 14122-4 a max. distance of ≤ 12 m between two rest platforms is allowed.

Rest platforms must not be used for work activities that are carried out from the ladder!

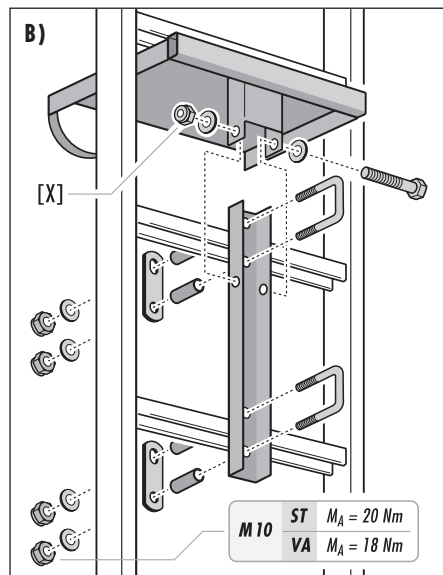
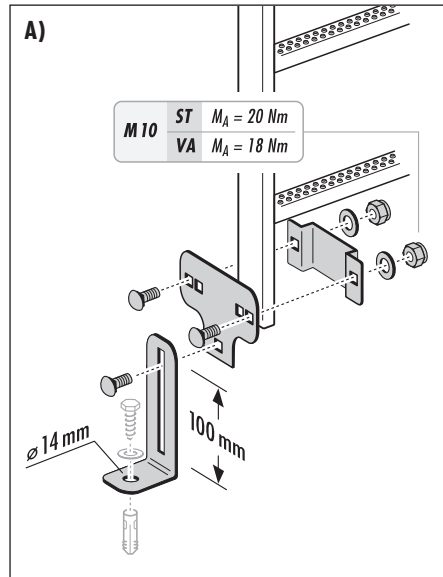

8. Mounting the Fixed Ladder

8.6 Installation Example: Basic and Expansion Platform

Basic and expansion platforms

(DIN EN ISO 14122-4, DIN 18799-1, DIN 14094)

Material: stainless steel or galvanized steel.

The Hailo platforms are suitable for accessing emergency exits and escape ladders, as well as working or rest platforms.

The substructure is made of solid sectional steel with slanted supports and stable grating, the safety railing has a circumferential knee and foot railing.

The basic platform can be extended by any number of extension platforms.

Basic platforms - Dimensions (width x depth):

1000 mm x 1200 mm	800 mm x 1000 mm
1000 mm x 1000 mm	800 mm x 800 mm
1000 mm x 800 mm	

Extension platforms - Dimensions (width x depth):

1000 mm x 1200 mm	800 mm x 1200 mm
1000 mm x 1000 mm	800 mm x 1000 mm
1000 mm x 800 mm	800 mm x 800 mm
600 mm x 1200 mm	
600 mm x 1000 mm	
600 mm x 800 mm	

Assembly of the basic and expansion platforms:

1. Attach the support to the substructure.
2. Screw the base platform together with the extension platform
3. Mount the safety railing to the substructure and screw them together.
4. Screw the grating to the substructure with clamping elements.

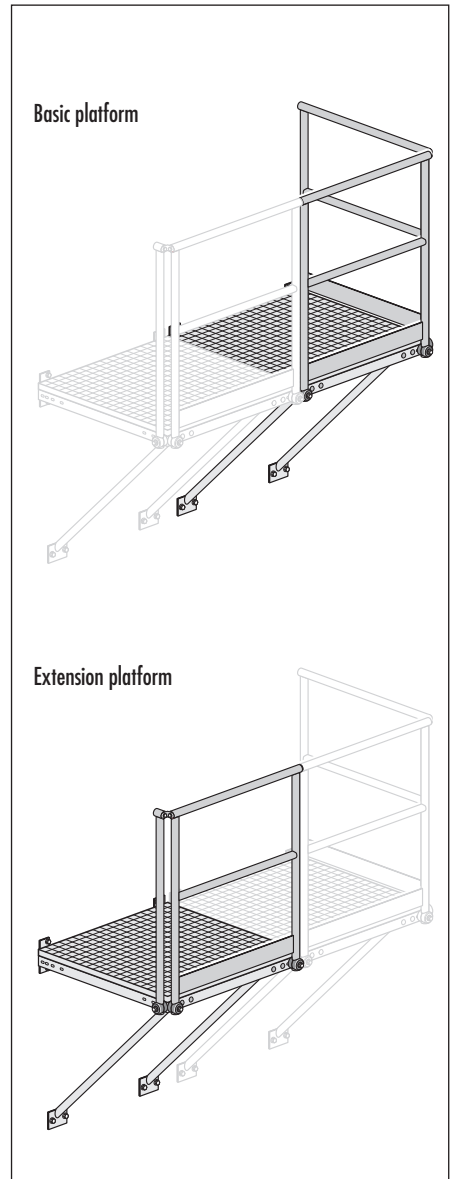

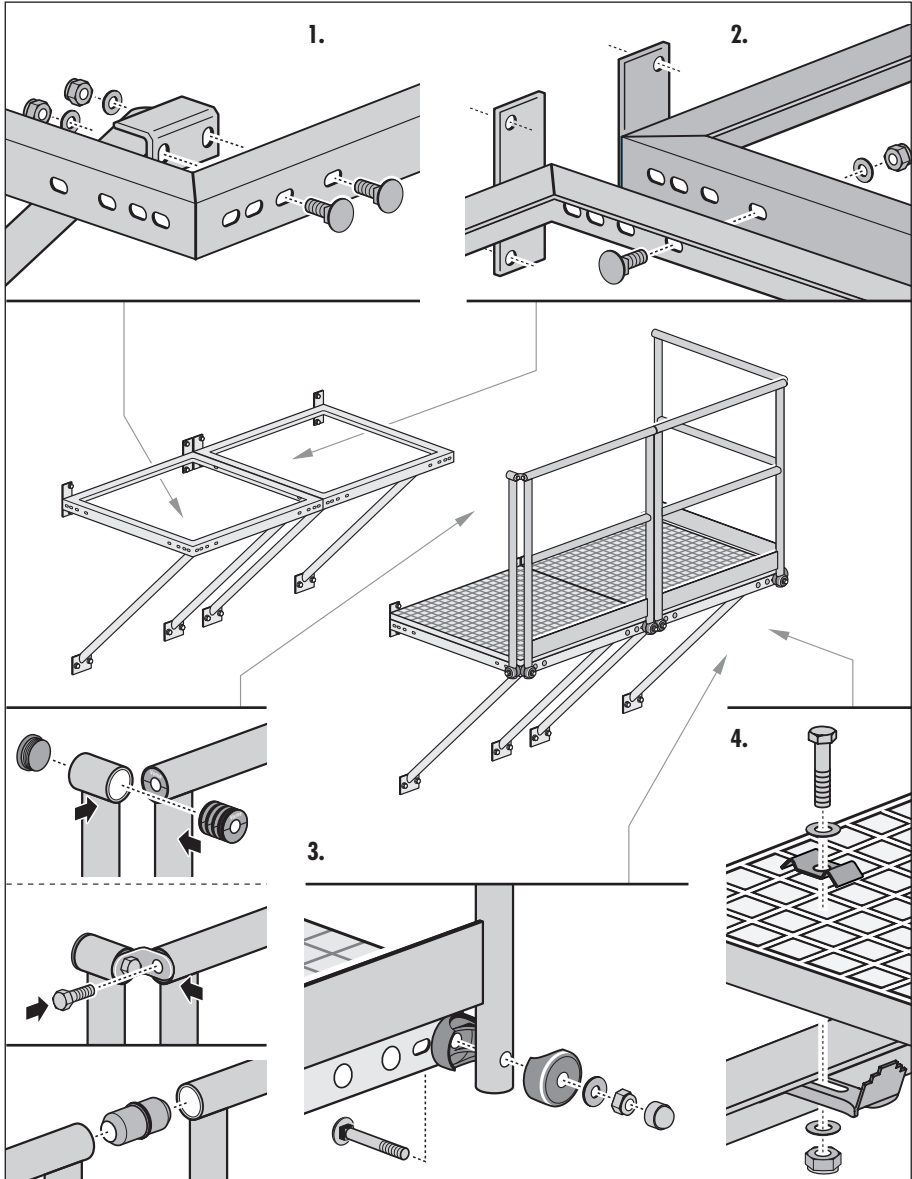

8. Mounting the Fixed Ladder

8.6 Installation Example: Basic and Expansion Platform

Base and extension platform with 45° support

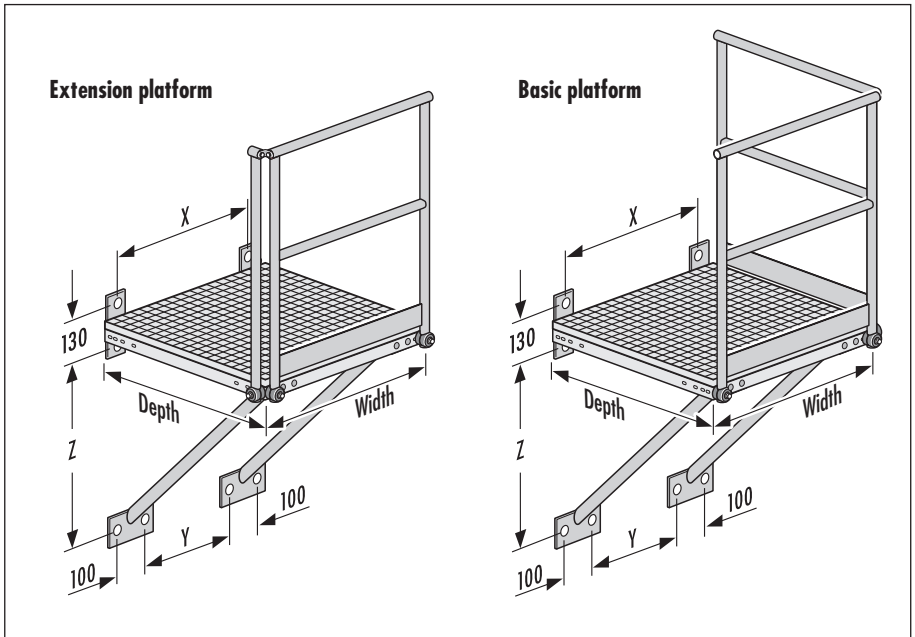

Width	X	Y
1000 mm	885 mm	610 mm
800 mm	685 mm	410 mm
600 mm	485 mm	210 mm
Depth	Z	
1200 mm	1115 mm	
1000 mm	915 mm	
800 mm	715 mm	

Width	X	Y
1000 mm	885 mm	610 mm
800 mm	685 mm	410 mm
Depth	Z	
1200 mm	1115 mm	
1000 mm	915 mm	
800 mm	715 mm	

Base and extension platform with 30° support

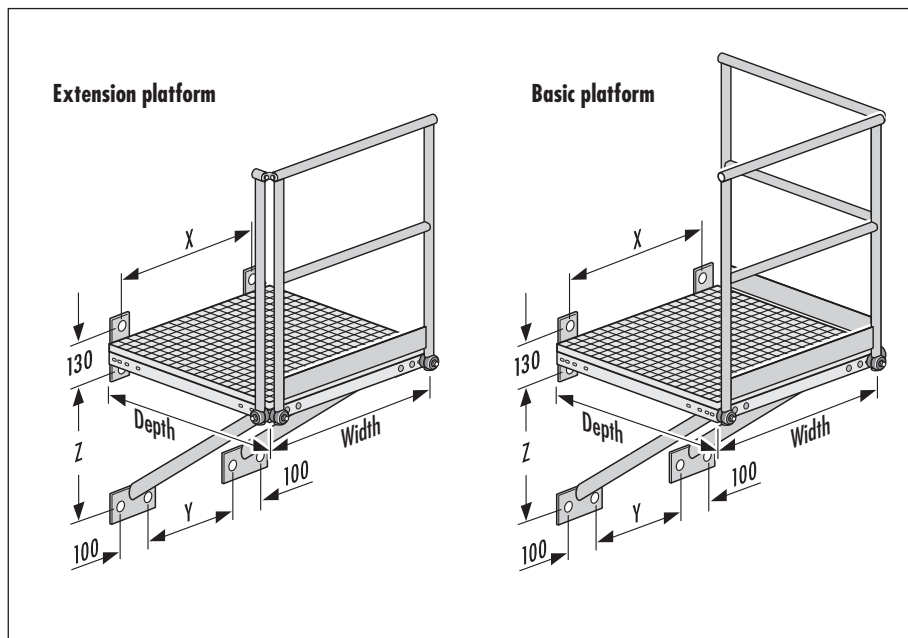

Width	X	Y
1000 mm	885 mm	610 mm
800 mm	685 mm	410 mm
600 mm	485 mm	210 mm
Depth	Z	
1200 mm	605 mm	
1000 mm	495 mm	
800 mm	375 mm	

Width	X	Y
1000 mm	885 mm	610 mm
800 mm	685 mm	410 mm
Depth	Z	
1200 mm	605 mm	
1000 mm	495 mm	
800 mm	375 mm	

9. Labels and Notes

Examples of markings on the fixed ladder:

Please take special note of all markings and stickers with safety notes and safety instructions.

A) Nameplate of the ladder

Year of manufacture, materials and dimensions, as well as instructions on the maximum load of the ladder.

B) Nameplate of the back protection system

Year of manufacture and material specification.

C) Identification plate of the ladder

Examination of the ladder at least once annually by an expert, documented with an inspection plate.

D) Manufacturer sticker



Also, customized safety and information labels may be used, which are not described or illustrated in this manual.

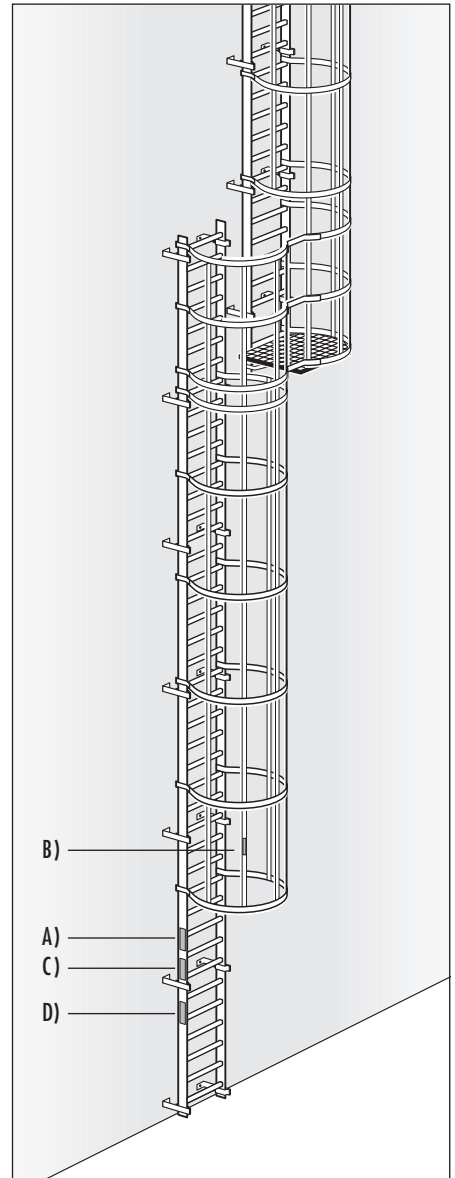

A)

Stahl Steigleiter Steel vertical ladder

**Typ: STO-40 MA
STO-40 BA**
Material: ASTM A36

Die Typenbezeichnungen sind aufgrund der Einsatzbereiche verschieden.
Bitte beachten Sie die Montageanleitung.
The type designations vary according to the areas of use.
Please comply with the operating instructions.

Holm/Teil: 40 x 20 mm
Sprossen/Rungs: 30 x 30 mm
Leiternbreite/Ladder width: 450 / 490 mm
Zulässige Belastung: Gewicht = 150 kg
Permitted load: Weight = 330 lbs

Herstelljahr
Year of construction
2022
EN ISO 14122-4
DIN 18799-1
DIN 14094-1

GEPRÜFT
DIN EN ISO 14122-4:2014
TUV AUSTRIA SERVICES GMBH
NB 0408

Hailo-Werk - Rudolf Loh GmbH & Co. KG
Daimlerstraße 8 - 35708 Haiger - Germany
www.hailo.de

1198799-1122

Edelstahl Steigleiter Stainless steel vertical ladder

**Typ: VAO-40 MA
VAO-40 BA**
Material: ASTM 304

Die Typenbezeichnungen sind aufgrund der Einsatzbereiche verschieden.
Bitte beachten Sie die Montageanleitung.
The type designations vary according to the areas of use.
Please comply with the operating instructions.

Holm/Teil: 40 x 20 mm
Sprossen/Rungs: 30 x 30 mm
Leiternbreite/Ladder width: 450 / 490 mm
Zulässige Belastung: Gewicht = 150 kg
Permitted load: Weight = 330 lbs

Herstelljahr
Year of construction
2022
EN ISO 14122-4
DIN 18799-1
DIN 14094-1

GEPRÜFT
DIN EN ISO 14122-4:2014
TUV AUSTRIA SERVICES GMBH
NB 0408

Hailo-Werk - Rudolf Loh GmbH & Co. KG
Daimlerstraße 8 - 35708 Haiger - Germany
www.hailo.de

1198799-1122

ALU Steigleiter ALU vertical ladder

**Typ: ALO-72 MA
ALO-72 BA**
Material: Aluminium

Die Typenbezeichnungen sind aufgrund der Einsatzbereiche verschieden.
Bitte beachten Sie die Montageanleitung.
The type designations vary according to the areas of use.
Please comply with the operating instructions.

Holm/Teil: 72 x 25 mm
Sprossen/Rungs: 30 x 30 mm
Leiternbreite/Ladder width: 440 / 490 mm
Zulässige Belastung: Gewicht = 150 kg
Permitted load: Weight = 330 lbs

Zertifikat-Nr.:
5011028.16002

Gültig nur in Verbindung mit Hailo-Holm- und Leiternbauteilen.
Only valid in connection with Hailo ladders and ladders components.

EN ISO 14122-4
DIN 18799-1
DIN 14094-1

Herstelljahr
Year of construction
XXX

Hailo-Werk - Rudolf Loh GmbH & Co. KG
Daimlerstraße 8 - 35708 Haiger - Germany
www.hailo.de

1198799-16214

ALU Steigleiter ALU vertical ladder

**Typ: ALO-72 MA
ALO-72 BA**
Material: Aluminium

Die Typenbezeichnungen sind aufgrund der Einsatzbereiche verschieden.
Bitte beachten Sie die Montageanleitung.
The type designations vary according to the areas of use.
Please comply with the operating instructions.

Holm/Teil: 72 x 25 mm
Sprossen/Rungs: 30 x 30 mm
Leiternbreite/Ladder width: 370 / 420 mm
Zulässige Belastung: Gewicht = 150 kg
Permitted load: Weight = 330 lbs

Zertifikat-Nr.:
5011028.16002

Gültig nur in Verbindung mit Hailo-Holm- und Leiternbauteilen.
Only valid in connection with Hailo ladders and ladders components.

EN ISO 14122-4
DIN 18799-1
DIN 14094-1

Herstelljahr
Year of construction
XXX

Hailo-Werk - Rudolf Loh GmbH & Co. KG
Daimlerstraße 8 - 35708 Haiger - Germany
www.hailo.de

1198799-16214

D)

Hailo
Hailo-Werk
D-35708 Haiger
Tel. +49 (0) 2732 820 0
Fax. +49 (0) 2732 821 1541
www.hailo.de

1198799-1122

B)

Rückenschutz Rear safety cage

Typ: RS-STO
Material: ASTM A36

Herstelljahr
Year of construction
2022
DIN 18799-1
DIN 14094-1
EN ISO 14122-4

GEPRÜFT
DIN EN ISO 14122-4:2014
TUV AUSTRIA SERVICES GMBH
NB 0408

Hailo-Werk - Rudolf Loh GmbH & Co. KG
Daimlerstraße 8 - 35708 Haiger - Germany
www.hailo.de

1198799-1122

Rückenschutz Rear safety cage

Typ: RS-VAO
Material: ASTM 304

Herstelljahr
Year of construction
2022
DIN 18799-1
DIN 14094-1
EN ISO 14122-4

GEPRÜFT
DIN EN ISO 14122-4:2014
TUV AUSTRIA SERVICES GMBH
NB 0408

Hailo-Werk - Rudolf Loh GmbH & Co. KG
Daimlerstraße 8 - 35708 Haiger - Germany
www.hailo.de

1198799-1122

Rückenschutz Rear safety cage

Typ: RS-ALO
Material: Aluminium

Herstelljahr
Year of construction
2022
DIN 18799-1
DIN 14094-1
EN ISO 14122-4

Zertifikat-Nr.: 5011028.16003

Hailo-Werk - Rudolf Loh GmbH & Co. KG
Daimlerstraße 8 - 35708 Haiger - Germany
www.hailo.de

1198799-16214

C)

PROFESSIONAL

Nächste Prüfung im:
Next inspection:

www.hailo.de

1198799-16214

10. Maintenance and Care

Maintenance:

- In the event of unfavorable weather conditions, appropriate maintenance measures should be carried out at an early stage in order to avoid increased hazards, e.g. due to the formation of ice.
- Moving parts are to be oiled when necessary and occasionally the free movement of these parts should be checked.
- Damaged surfaces should be sealed with a suitable corrosion protection agent.

Cleaning:

- Impurities must be cleaned with a gentle cleaning agent.
Acids or alkaline based solutions must not be used.

11. Inspection of the Fixed Ladder

Standards information:

DIN 18799-1, DIN 14094-1, DIN EN ISO 14122-4.

Inspection intervals:

- Inspection intervals are to be carried out in accordance with the respective current national regulations.
- Inspections intervals in Germany:
Inspection intervals are based on frequency of use, stress during use and the frequency and severity of any defects that are identified.
- Recommendation:
Hailo recommends that fixed vertical ladders are inspected at least once a year.
- An inspection of the fixed ladder system is required at least every 3 years in accordance with DIN 14094-1!

Inspection:

The ladder system must be checked at least once a year for good condition and functioning by an expert / authorized person.

- An expert / authorized person is:
A person who has the necessary expertise to test the equipment owing to their apprenticeship, professional experience, their recent professional activity and who has undergone special training with the manufacturer.
- Inspections are to be carried out using the inspection schedule for fixed vertical ladders (see pages 52-55).



The individual national operating and auditing regulations are to be followed.

Information on vertical ladder system:

Inventar-Nr. :

.....

Stock no. :

.....

.....

.....

Design of vertical ladder:

- Vertical ladder with back protection
- Vertical ladder without back protection including fall arrest system* with fixed guide in accordance with EN 361
- Vertical ladder without back protection and without an EN 361-compliant fall arrest system

Material:

- Steel, galvanised
- Stainless steel
- Aluminium

Manufacturer:

.....

.....

.....

Date of commissioning:

.....

** A separate inspection is to be carried out for the fall arrest system in accordance with the manufacturer's instructions.*

12. Installation / Acceptance Report Fixed Ladder

Building project / property	
Name / Designation / Company	
Street / House no. - Postcode/ Town	
Date	Page

Customer / Contracting Authority / Operator	
Name / Designation / Company	
Street / House no. - Postcode/ Town	
Contact partner	
Telephone /Mobile - E-mail	

Contractor
Name / Designation / Company
Street / House no. - Postcode/ Town
Contact partner
Telephone /Mobile - E-mail

Assembly company
Name / Designation / Company
Street / House no. - Postcode/ Town
Contact partner
Telephone /Mobile - E-mail

Responsible architect
Name / Designation / Company
Street / House no. - Postcode/ Town
Contact partner
Telephone /Mobile - E-mail

External expert / structural engineer
Name / Designation / Company
Street / House no. - Postcode/ Town
Contact partner
Telephone /Mobile - E-mail

Order data
Contracting Authority
Order number
Date

Contractor
Order number
Date

Attachments

12. Installation / Acceptance Report *Fixed Ladder*

General information regarding the vertical ladder	
Vertical ladder - Material -	
Wall bracket + Accessories - Material -	
Height	
Assembly / design according to standard (please tick relevant box)	
DIN 18799 (construction facilities)	<input type="checkbox"/>
DIN EN ISO 14122 (machinery)	<input type="checkbox"/>
DIN 14094 (emergency ladders)	<input type="checkbox"/>
Back protection from . . . above ground level	
Rail-guided fall arrest device H-50, - Material -	
Cable-guided fall arrest device H-8, - Material -	
PPE (personal protective equipment) number	

Information on the mounting surface
Masonry / construction
Approach attempts Test report no. (as an attachment)
Attachments used
Assembly of the vertical ladder according to Hailo installation instructions (please tick the relevant box)
Yes <input type="checkbox"/> No <input type="checkbox"/>
Initial inspection of the vertical ladder carried out and documented according to the test plan (please tick relevant box)
Yes <input type="checkbox"/> No <input type="checkbox"/>

Complaints
Description of the complaint (To be eliminated by . . .)

Signatures

Customer / Contracting Authority

.....

.....

Name / Date / Signature

Assembly company

.....

.....

Name / Date / Signature

Contractor

.....

.....

Name / Date / Signature

Responsible architect

.....

.....

Name / Date / Signature

External expert / structural engineer

.....

.....

Name / Date / Signature

13. Inspection Plan

Test plan for periodic inspection of fixed ladders made of steel / stainless steel / aluminium

Periodic inspections are to be documented in the table on pages 54/55 by trained/authorised personnel.

In the event of a claim, this documentation must be submitted in full as evidence. The manufacturer must be granted access to this at all times.

Result:



1. Fixed vertical ladder in steel / stainless steel / aluminium:

- | | | |
|-----|-----------------|--|
| 1.1 | Ladder uprights | Technical condition, damage, distortion, corrosion, cracks, burrs |
| 1.2 | Ladder rungs | Technical condition, damage, distortion, corrosion, cracks, burrs
Rung/upright connection (welds), anti-skid protection |

2. Ladder fixings:

- | | | |
|-----|---|--|
| 2.1 | Anchorage points | Steel-threaded rings: technical condition, preload force, torque
On concrete base: condition of concrete base
On other materials: structural condition |
| 2.2 | Bolt connections | Technical condition, property class, preload force, torque |
| 2.3 | Ladder brackets | Technical condition, suitability of fastening fixtures, damage, deformation, corrosion |
| 2.4 | Ladder connectors | Technical condition |
| 2.5 | Suspension supports/tension braces (where fitted) | Technical condition |

3. System components:

- | | | |
|-----|---|--|
| 3.1 | Back protection components | Technical condition, quality of fixings, damage, distortion, corrosion |
| 3.2 | Entry/exit elements | Technical condition, damage, corrosion |
| 3.3 | Folding rest platform (no.: ___ pcs.) | Quality of fixings, function, damage corrosion |
| 3.4 | Base/extension platforms (where fitted) | Technical condition, damage, corrosion |

4. Markings:

- | | | |
|-----|-----------------------------------|---|
| 4.1 | Vertical ladder original markings | Vertical ladder, system components, fall arrest device (where fitted)
Markings present and legible |
| 4.2 | Inspection documentation | Confirmation of the test, test badge |



1207509 • 02/2024 Rev. 08 • Technical changes reserved

Hailo-Werk • Rudolf Loh GmbH & Co. KG • Daimlerstraße 2 • 35708 Haiger, Germany

 +49 (0) 2773 82-0 •  +49 (0) 2773 82-1218 • www.hailo-professional.de • E-Mail: professional@hailo.de